

Minebea Group CSR Report 2012



Contents

Contents•Editorial Policy•Corporate Profile	1
Commitment from the President	3
Damage from Thai Floods and Response	5
Minebea Products in Society	7

Special Feature 1	Ball Bearings Pursuing the Limits of Precision	9
--------------------------	---	---

Special Feature 2	Developing CSR Together with Suppliers	13
--------------------------	---	----

Management Report

Minebea Group CSR	17
Corporate Governance	18
Compliance	19
Risk Management	20
CSR Promotion Activity Goals and Results	21

Social Report

Relationships with Customers	23
Relationships with Employees	25
Relationships with Local Communities and Global Society	29
Relationships with Suppliers	31
Relationships with Shareholders	32

Environmental Report

Environmental Management	33
Initiatives for Preventing Global Warming	36
Initiatives for Effective Use of Resources	37
Initiatives for Reducing Impacts on the Environment	38
Product-related Initiatives for the Environment	39
Third-party Opinion	40

Editorial Policy

We publish the Minebea Group CSR Report annually as a way to inform our stakeholders of our Group's CSR approach and initiatives. This year, in addition to explaining key initiatives representative of our efforts in a CSR Report, we have supplemented the report with information on our corporate website on various other activities and detailed data.

For the third year of the publication of the CSR Report, we conducted a review of the CSR goals for FY2011 established last year. Based on this review, we have formulated new FY2012 and medium-term CSR goals which are disclosed in the Management Report.

Thailand, where Minebea Group's main manufacturing facilities are located, suffered from flooding in FY2011, and our sites were also damaged. This report provides information on the damage to our facilities and our response.

We consider the publication of the CSR Report to be one important means of communication with stakeholders, and in keeping with this approach, we have endeavored to make the contents relevant and clear. We are always pleased to receive forthright comments from our readers on our CSR activities.

■ Scope of report

Minebea and its 44 group companies

■ Period covered by this report

FY2011 (April 1, 2011–March 31, 2012)

However, this includes some activities before this period and from FY2012.

■ Publishing information

Published September 2012 (previous edition published September 2011; next edition planned for September 2013)

■ CSR website URL

<http://www.minebea.co.jp/english/environment/index.html>

■ Reference guidelines

Japanese Standards Association, ISO 26000:2010 (guidance on social responsibility)

GRI "Sustainability Reporting Guidelines" (edition 3.1)

Japanese Ministry of the Environment "Environmental Reporting Guidelines" (2007 edition)

■ Enquiries regarding this report

CSR Promotion Office, Corporate Finance & Compliance Promotion Division, Minebea Co., Ltd. TEL: +81-3-5434-8653

Corporate Profile (as of March 31, 2012)

Corporate name	Minebea Co., Ltd.
Headquarters	4106-73 Oaza Miyota, Miyota-machi, Kitasaku-gun, Nagano 389-0293, Japan TEL: +81-267-32-2200
Tokyo head office	19F Arco Tower, 1-8-1 Shimo-Meguro, Meguro-ku, Tokyo 153-8662, Japan TEL: +81-3-5434-8611
Established	July 16, 1951
Capital	68,258 million yen
Representative	Yoshihisa Kainuma, Representative Director, President and Chief Executive Officer
Main business	Machined components business, rotary components business, electronic devices and components business, and others
Net sales	Consolidated: 251,358 million yen
Operating income	Consolidated: 8,599 million yen
Ordinary income	Consolidated: 6,499 million yen
Net income	Consolidated: 5,922 million yen
Number of employees	51,406 persons
Number of consolidated subsidiaries and affiliates	40 companies

■ Net sales by business segment (FY2011)

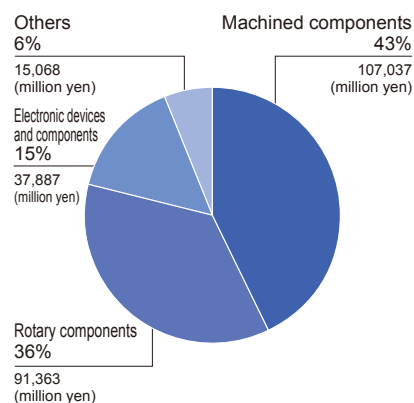

■ Total production by region (FY2011)

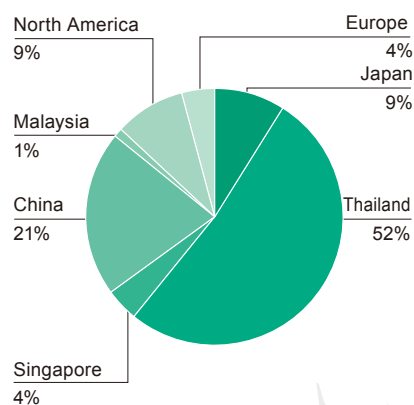

■ Net sales

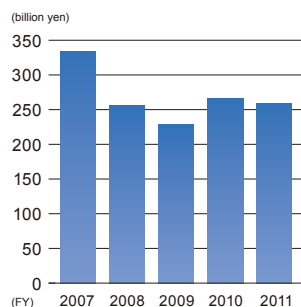

■ Operating income

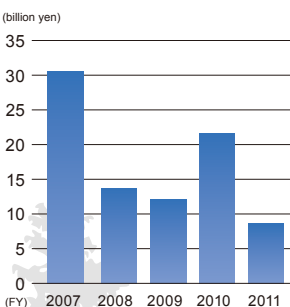

■ Ordinary income

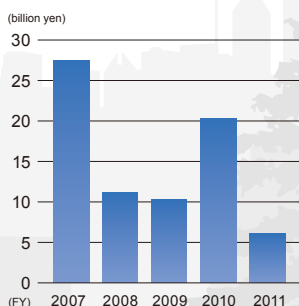

■ Net income

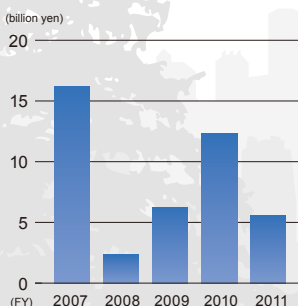

■ Net sales by region (FY2011)

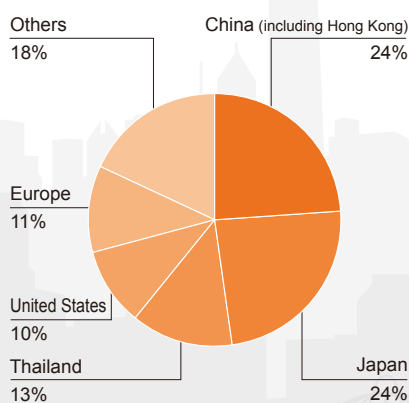

Commitment from the President

Looking Back on FY2011

The Minebea Group Basic CSR Policy states: "As a manufacturer of precision products supporting society, the Minebea Group is working toward stable supply and making reliable products with low energy consumption widely available, to contribute to the sustainable development of the global environment and of humanity." FY2011 was a year in which both our long-held commitment to "manufacturing with sincerity" and our Basic CSR Policy were put to the test.

The nuclear power plant accident precipitated by the Great East Japan Earthquake caused a paradigm shift in the nation's entire socio-economic structure regarding domestic demand and supply for energy. Debates are being held on a national level about how the required amount of energy can be supplied and how best to distribute this energy. The need to reduce energy consumption has become an urgent concern shared among all, from industry to individuals.

At Minebea, we recognize that the enhancement of the products we manufacture both directly and indirectly impacts the reduction in energy consumption. We are committed to continuing the development of safe, energy-efficient, and resource-efficient products.

The Great East Japan Earthquake severely disrupted industrial supply chains, including our own. In Thailand, meanwhile, flooding caused damage to two of our five manufacturing sites, and brought about serious consequences including long suspensions of operations at the local facilities of many companies including other Japanese corporations in the affected region. These unforeseen natural disasters challenged us to overcome a host of issues, including the loss of power and other core infrastructure, disruption and disorder to manufacturing and distribution, as well as the upheaval caused to the lives of our employees.

Our Thai manufacturing sites produce a number of products with high global market shares, which is not only a key source of the corporate value for the Minebea Group, but also brings with it a significant supplier responsibility. To fulfill our obligations in this regard, we responded to the Thai floods by implementing a Group-wide business continuity plan (BCP) which included emergency responses to the flooding of manufacturing facilities, securement of heavy machinery and manufacturing equipment, measures to quickly restore operations, and steps to ensure the safety and transportation means of employees. We implemented



Yoshihisa Kainuma
Representative Director
President and Chief Executive Officer
Minebea Co., Ltd.

response measures in accordance with our Basic CSR Policy, restarting manufacturing only after conducting research and verifying that during the process of restoring operations, the massive flooding had not impacted the environment.

Furthermore, in January 2012, we announced our participation in the UN Global Compact as part of our CSR activities. The Minebea Group prides itself on being a global organization, boasting operations around the world and a diverse workforce of dedicated employees working hard together through close communication to raise the value of our manufacturing capabilities. As a global organization, it is natural for the Minebea Group to abide by the Global Compact's 10 principles as a way of fulfilling our social responsibility. We have always been progressive in fulfilling this obligation, and the participation in the Global Compact will only spur us to raise our sights higher.

FY2011 was also a year in which we embarked on new CSR challenges. We formulated the CSR Procurement Guidelines in order to strengthen our relations with suppliers and promote our CSR activities throughout the supply chain. Additionally, we are conducting supplier dialogues as a way to encourage

frank opinion exchanges with our suppliers. These new initiatives are promoting a better understanding of the Minebea Group's approach to manufacturing and creating new opportunities for exchanges of views. The holding of these dialogues with many suppliers is the first step in our initiative to mutually enhance our CSR programs and build a socially responsible global procurement scheme by FY2015.

In the area of the environment, we have revised our Environmental Philosophy as the Minebea Group Environmental Policy. We have enhanced the policy by disclosing our environmental protection technologies, as well as by making a commitment to contribute to international society through awareness of the potential impact of our business activities on biodiversity and through efforts to protect nature.

Last year, the establishment of our medium-term CSR goals was brought up by third-party experts, and based on an evaluation of the results of goals set in FY2011, we formulated new goals for FY2015. Moving forward, we will strive to accelerate progress on achieving our medium-term CSR goals.

Fulfilling Our Responsibility as a Supplier Based on "Manufacturing with Sincerity"

During the floods in Thailand, I joined the local response headquarters and took charge of the response team. At our manufacturing sites, I saw all our employees take part in efforts to confront the disaster with the conviction that they were protecting their own workplace. Each day, under the burning sun, more than 3,000 employees collaborated to build embankments against the floodwaters, and despite the hardship, they never lost their good spirit.

The first of the "Five Principles" which make up Minebea's basic management policy is, "Be a company where our employees are proud to work." It was during this flood response that I had the opportunity to see just how deeply ingrained this principle is. I was encouraged by how this strong sentiment had become the driving

force that enabled the employees to overcome the crisis.

We are still facing a severe business environment, but overcoming the crisis has united us and provided new momentum as we enter the first year of the new Medium-term Business Plan.

The core strength of the Minebea Group has always been our belief in "manufacturing with sincerity." People are what make this possible. We will leverage the superior know-how and capabilities developed over the years to continue to expand in global markets. At the same time, we will use this know-how to establish a Group-wide BCP and reinforce our operations to ensure that we can fulfill our responsibility as a supplier to customers throughout the world.

Aiming for Sustainable Growth in Step with Society

Since being appointed president, I have focused my energies on enhancing the comprehensive capabilities of the Minebea Group. More than ever, I feel that the key to promoting "manufacturing with sincerity" lies in the passion each employee has for manufacturing and their collective hard work. To commemorate the 60th anniversary of the company, we have created a new corporate message to embody this idea: "Passion to Exceed Precision." This message reflects our employees' passion towards raising precision levels and achieving ultra-precise manufacturing, as well as for realizing a new manufacturing model that surpasses standard components manufacturers. This message will be a new slogan for our commitment to sustainable growth as a global corporate citizen and the various activities we undertake with passion to realize our goal.

My hope is that the publication of the Minebea Group CSR Report enables all of our stakeholders to see the progress we are making in our business activities and our CSR initiatives. We look forward to comments from many stakeholders and will strive to reflect the comments in our future business activities.

Supporting the UN Global Compact

UN Global Compact

The UN Global Compact was launched in 2000 based upon a proposal by former Secretary-General Kofi Annan. Clearly supported by current UN Secretary-General Ban Ki-moon, the UN Global Compact is a United Nations initiative in which businesses demonstrate responsible and creative leadership and voluntarily participate in efforts to establish a worldwide framework that enables them to act as good corporate citizens and achieve sustainable growth.

The UN Global Compact is comprised of 10 principles promoting the protection of human rights, the elimination of unfair labor practices, the protection of the environment, and anti-corruption. More than 10,000 organizations (including approximately 7,000 companies) worldwide have adopted these principles and continue to take measures to achieve them.





Food is distributed at evacuation centers.



Food and water are distributed to local residents; Boats are used for distribution because nearly all roads but major highways are flooded.



To accelerate the restart of operations, employees carry out maintenance activities despite pools of water remaining on the plant floor; Without power, employees labor amid hot and humid conditions.



Inside a double embankment on the west side of the Bang Pa-in Plant, pumps are used to manage the water levels in a water pressure adjustment pool.

Response to Stakeholders

● Response to Customers

The Minebea Group strove to fulfill its responsibility of supplying customers by temporarily increasing inventories as well as increasing outsourcing of product manufacturing. In order to ensure that product shipments reached planes and ships by their departure times, employees confirmed the status of regular transport routes and traffic information and shared the information with other departments to adjust the shipment times from the plants.

The Local Countermeasures Office used a company helicopter to survey floodwater status almost daily. Responding to customer requests, the helicopter was also used to check areas around customer sites. The Management Headquarters in Japan collected information and made six public announcements to keep stakeholders informed of the status of damage.

● Support for Local Residents

The flooding also caused severe damage to the residential areas and lives of people living around the Group's plants. The Group supported residents around the plant by distributing emergency relief goods and sandbags. The Bang Pa-in Plant also stationed Thai army units and provided logistics support for the units in their relief activities. The Group will continue to support residents as they recover from the disaster.

● Employee Cooperation Makes Flooding Countermeasures Possible

The support of many Group employees was critical to the construction of earth embankments, water drainage, and other countermeasures which helped to minimize the

damage to the Group's facilities. Employees demonstrated a high level of motivation to protect their own workplace, with the number of volunteers exceeding the number recruited. Many employees gladly worked on holidays and during the night to protect the facilities.

The Group thoroughly managed the safety and health of its employees to prevent secondary damage. Open spaces in the plant were used as relief shelters for some 500 employees unable to commute or return to their homes. The Group also reassigned employees from the Rojana and Navanakorn Plants, where operations were suspended, in order to maintain the employment of all the employees. The employees' recognition of the Group's commitment to their employment and safety not only deepened the bonds of trust, but created a source of strength to help the Group overcome the disaster.

The Group provided consolation funds to approximately 13,000 employees affected by the disaster, and donations collected from Group worksites around the world were donated to repair and rebuild the homes of 146 employees who suffered particularly severe damage.

● Environmental Surveys

The Group confirmed the leakage of oil and chemical substances from machinery and washing equipment and disposed of the waste oil and fluids, along with dried sludge containing oil, in accordance with environmental regulations. The Group also conducted water quality and soil tests at each of the local plants, and has confirmed that the amounts of heavy metals, chemical and other substances are within safe ranges which will not impact the environment.

Reconstruction Activities and Countermeasures Against Future Natural Disasters

Based on the lessons learned from the flooding, the Minebea Group is striving to reinforce its countermeasures and prepare for the possibility of future floods.

The restoration of the damaged Rojana and Navanakorn Plants is scheduled to be completed in September 2012 following the total replacement of machinery, maintenance to the facilities, and the cleaning of the inside and outside of the buildings. Both the plants are located in industrial parks which are strengthening their own flooding countermeasures (construction of embankments). The plants are taking independent initiatives, however, which include the reinforcement of buildings with steel plates to prevent water from entering. The Bang Pa-in and Ayutthaya Plants, meanwhile, used water level data from the 2011 floods to construct new embankments which can withstand floods three-to-four times the previous size (construction completed in July 2012).

In addition to the direct impact of the floods, the inability of employees to commute to work and unstable power supplies also contributed to periods of lower operational capacity at the plants. The Group will use this experience to bolster future countermeasures, including the establishment of backup structures at other plants to fulfill the Group's responsibility of supplying customers, as well as the reformulation of the inventory strategy.

One of the most valuable experiences from the disaster was the strengthening of the Group's unity through the demonstration of employees' strong desire to protect their company and collaborate to overcome the disaster. This new sense of unity will be leveraged to bolster countermeasures against future disasters.



Many employees continuing recovery activities after dark.



Metal molds recovered by divers at the Rojana Plant, an important step in restarting the manufacturing of parts.



Employees unable to return to damaged homes take temporary shelter at the new bearing plant; Employees living in temporary shelters continue daily work and assist with anti-flooding countermeasures.



The newly constructed embankment at the Bang Pa-in Plant.

Minebea Products in Society

The ball bearings, motors, and electronic devices that we manufacture are incorporated in a wide range of final products, improving the lives of people around the world, and helping to bring about a richer society. Although our products are not normally visible to consumers, this page will introduce the role they play in society.

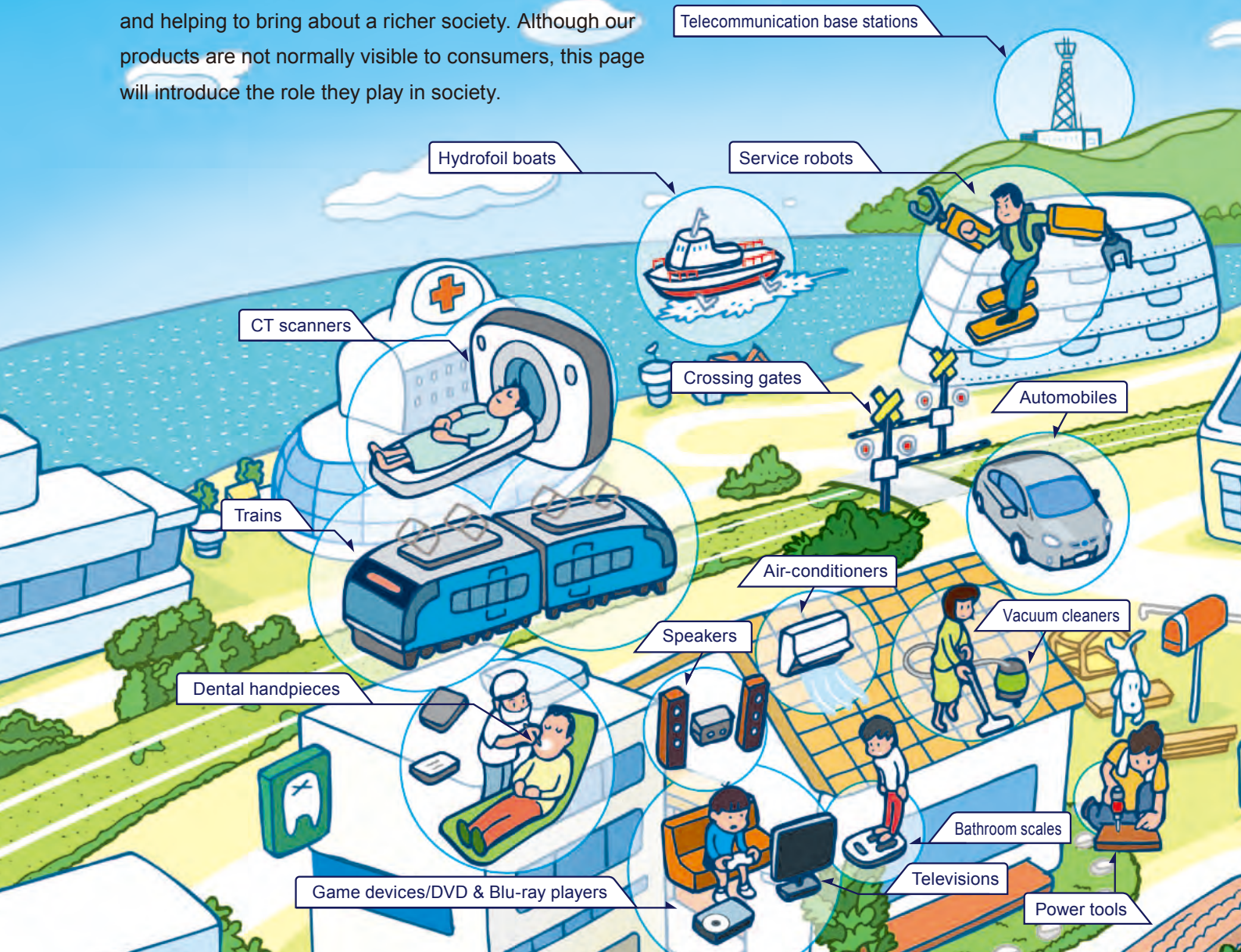

Machined components

● Products

Ball bearings, rod end & spherical bearings, roller bearings, fasteners, pivot assemblies, precision machined components

● Product applications

Personal computers, hard disc drives, information and telecommunications equipment, OA equipment, consumer electronics, audio-visual equipment, ATMs, automobiles, aircraft



Rotary components

● Products

Hard disc drive spindle motors, small precision motors, stepping motors, brushless motors, fan motors

● Product applications

Personal computers, hard disc drives, information and telecommunications equipment, OA equipment, consumer electronics, mobile phones, audiovisual equipment, mobile phone communication base stations, industrial machinery, automobiles





Electronic devices and components

● Products

Lighting devices for small liquid crystal displays, color wheels, backlight inverters, various measuring components, heat management system module (HMSM), next-generation input devices

● Product applications

Personal computers, digital cameras, mobile phones, smartphones, portable music players, projectors, measuring equipment, automobiles, space rockets, service robots

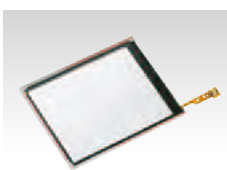

Others

● Products

Speakers, special components

● Product applications

Personal computers, speakers, audio-visual equipment, industrial equipment, defense equipment





Ball Bearings Pursuing the Limits of Precision

The history of the Minebea Group is a chronicle of daily challenges in manufacturing with sincerity. This feature provides insight into how the Minebea Group's manufacturing philosophy was developed through the manufacture of ball bearings.

Japan's First Manufacturer Specialized in Miniature Ball Bearings

Minebea's history stretches back about 60 years to 1951, when the company began as Japan's first specialty manufacturer of miniature ball bearings with about 10 employees and a small factory.

At the time, miniature ball bearings were used mostly in aircraft instrumentation. Just after the Second World War, however, there were no Japanese manufacturers capable of producing this type of high-precision manufactured parts. The founders of Minebea decided to embark on the manufacture of miniature ball bearings based on the belief that aircraft demand would increase in the future, and that Japan needed the technological capability to manufacture this type of

high-precision product. The specialty of the product as well as the lack of adequate manufacturing equipment posed significant challenges for the founders, who relied on trial and error to overcome obstacles.

Despite the challenges, Minebea successfully established its manufacturing technology in the late 1950s thanks to the efforts of Japanese engineers. After the high-quality products were recognized in the U.S. market, Minebea's sales began to take off. In 1963, the company constructed the Karuizawa Plant and equipped it with state of the art machinery. This established the company's modern manufacturing foundation by enabling mass production of high-quality products. To respond to rising demand for Minebea products worldwide, the company expanded business to Singapore in 1972 and then to Thailand and China.

Today, the Minebea Group maintains eight ball bearing manufacturing plants worldwide, with approximately 10,000 employees involved in the business, and a monthly production of some 250 million ball bearings.



The company continued to grow through trial and error with President Seiichiro Takahashi at the helm



Expansion work on the Karuizawa Plant in the 1960s

The Function of Ball Bearings

From car axles to electric fans and hard disc drives (HDDs), ball bearings are used in a wide array of machines for rotary motion. Ball bearings support rotary parts and reduce friction to facilitate the smooth operation of machines. The size of ball bearings can range from smaller than a grain of rice—small enough to fit inside a wristwatch—to over one meter in diameter for factory and power plant applications. Minebea specializes in the manufacture of miniature and small-sized ball bearings with an outer diameter of 30mm or less.

Structure of Ball Bearings

Ball bearings are comprised of four major parts: a large ring (outer ring), a small ring (inner ring), balls between the rings (steel balls), and a cage to prevent the balls from hitting each other. The modern structure dates back to around 1500, when Leonardo da Vinci invented ball bearings to reduce friction against the axles of horse-drawn carts. For more than 500 years, the ball bearing has been defined by this simple structure.

The Precision of a Ball Bearing

The main function of a ball bearing is to reduce friction and facilitate smooth rotation of an axis. Modern ball bearings test the very limits of precision. As an example, one of the key elements to making an ultra-precise ball bearing is the degree to which the groove where the balls roll can be made into a perfect circle. Minebea has achieved ultra-precision groove manufacturing which reduces the range of error from a perfect circle to one-one hundred thousandth of a millimeter.

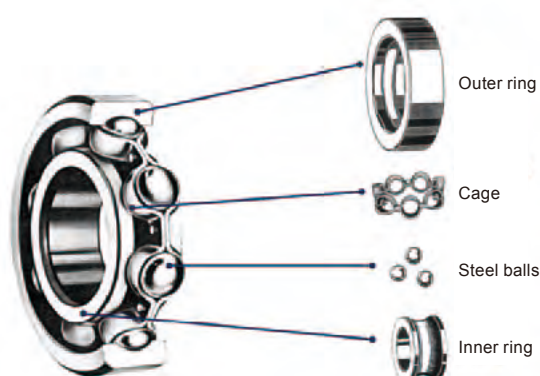
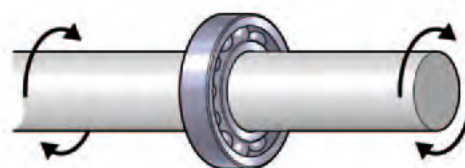

An Endless Passion for High-quality Manufacturing

The most important performance measure in judging a ball bearing is the extent to which it reduces friction and facilitates smooth and easy rotation. Ball bearings may end up in aircraft, automobiles, precision machinery and many other end products, but no matter the application, it is important to maintain smoothness and minimize friction. Changes in the times brings diversification and complexity in end products and machine types along with new performance requirements for ball bearings, including miniaturization, higher rotation speeds, durability and duration, as well as noise reduction.

We have succeeded in responding to new requirements by carefully reviewing all of our product processes, from development and design to manufacture and inspection, and making steady, painstaking improvements. Since the structure of a ball bearing is very simple, however, improving the ball bearing has required enhancing the precision of the ball bearing components to their absolute limit. In order to do this, we decided to manufacture not only the critical inner and outer rings in-house, but the other components as well. Currently, Minebea also manufactures the cage, shield, and balls in-house. Additionally, to ensure the smooth rotation of the ball bearings, we have developed proprietary lubricants. We have also developed in-house a grinding machine which can be controlled to sub-

micrometer (one-ten thousandth of a millimeter) precision, along with assembly equipment. To vertically integrate the business, we have enhanced the sophistication of the manufacturing capability and automated the manufacturing line. Today, nearly all the manufacturing equipment used in the grinding, polishing, and assembly processes were developed in-house.

While the design and quality of a product may be outstanding, if the price is too high, customers won't buy it. To improve cost-competitiveness, we evaluate the manufacturing processes from every angle, and strive to shorten the time from order to delivery while raising the yield. Another way we strive to beat the competition on price is to invest heavily in machine maintenance to ensure that our manufacturing equipment operates in optimal condition. This is another benefit of vertically integrating our business.

▶ Annual Ball Bearing Production

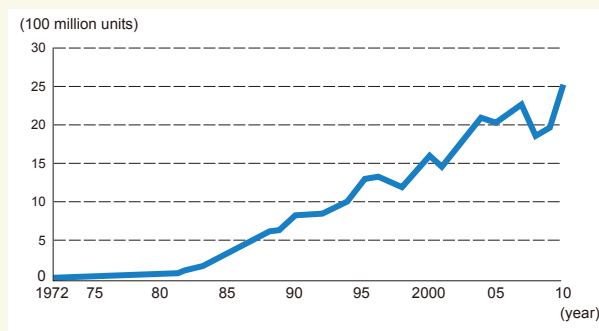

Ball Bearing Manufacturing Processes

The manufacture of a ball bearing can be divided into five major processes.

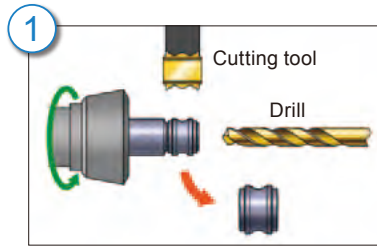

1 Cutting
Ring-shaped parts are cut from the raw material rods using drills and cutting tools.

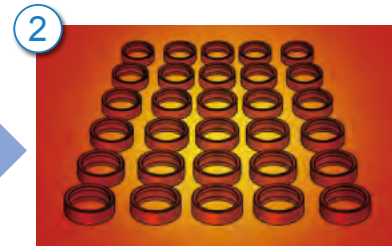

2 Heat Treatment
Process for hardening the parts in order to enhance their durability and long-life.

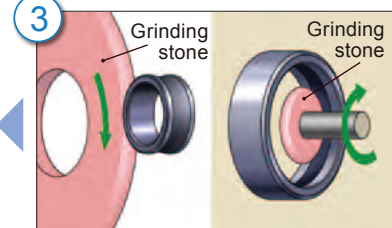

3 Grinding
A grinding stone is used to grind the surfaces of parts to the required dimensions and precision. Dimensions such as the outer and inner diameters and the width are ground to micrometer (one-thousandth of a millimeter) precision, as is the groove, a key internal structure formed between the inner and outer rings in which balls run.

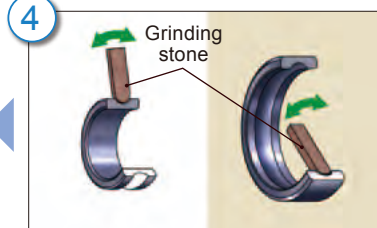

4 Honing
The groove between the outer and inner rings in which the balls run is honed to nanometer (one-thousandth of a micrometer) precision.

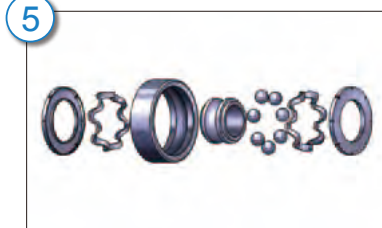

5 Assembly Process
The outer ring, inner ring, balls and cage are assembled, oil or grease is applied to aid smooth rotation, and covered by a shield. This is the process where exactly the right parts are assembled to meet the customer's specific requirements.

Manufacturing Uniform Products Around the World

The manufacture of miniature ball bearings requires extremely delicate and sophisticated precision, and simply using the same materials and manufacturing equipment does not guarantee that uniform products will be produced. Minebea has introduced a proprietary “warp and weft” approach to ensure that all of its eight manufacturing plants worldwide produce a uniform quality of products.

The “warp” in this system is the vertical examination of all the manufacturing processes along the machine direction by each plant manager to ensure thorough manufacturing management on the basis of Minebea’s long-accumulated integrated manufacturing know-how. The “weft” in this system is the dispatch of managers for each of the manufacturing processes from the

Karuizawa Plant, the “mother plant,” to the seven overseas plants to ensure with an objective eye that processes are horizontally deployed throughout the world. One of the features of this system is the frequent visits by the Karuizawa Plant managers to the overseas plants, much as if they were visiting a plant next door, to oversee and train local employees. The combination of this warp and weft enables Minebea to achieve a manufacturing system which guarantees uniform products and high productivity.

The implementation of uniform product manufacturing may appear as though Japanese methods are being thrust unilaterally on overseas sites. At Minebea, however, we have established basic policies of respecting the culture and customs of local communities to the extent possible when localizing our product manufacturing. We actively promote local employees to management positions and operate local plants on the basis of locally developed management and employees. We believe that transplanting Japanese methods to local communities overseas is best achieved by customizing the methods to fit the local community to the extent possible. This enables know-how to be implemented overseas in a relatively short time.

An Image of the “Warp and Weft” Concept for Uniform Product Manufacturing

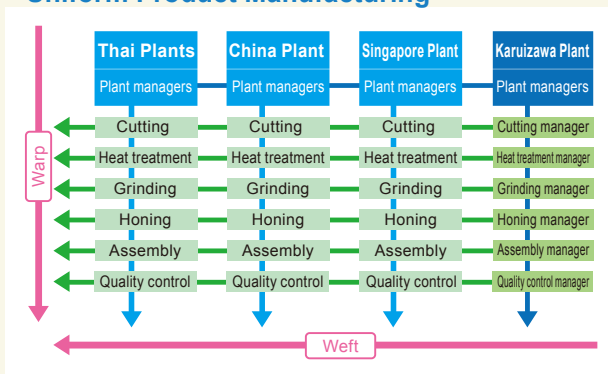

Sweating It Out Together to Build Teamwork

Minebea’s purpose in expanding its business overseas has never been simply to access labor pools. We have expanded from the standpoint of making a long-term investment to mass produce better products. Based on this policy, we install the latest machinery when

constructing new overseas plants and, as previously mentioned, we actively promote the localization of management. We also spare no effort in investing in the future through the time and effort put into employee training.

We believe that training employees works best by having them witness the processes firsthand at the manufacturing sites. When we construct new plants, we not only provide classroom training to local employees, but we provide practical on-the-job (OJT) training at operating plants. Following the OJT, engineers from the Karuizawa Plant visit each plant on a routine basis to provide direct, repeated training sessions to employees and share their know-how. In each of the plants, a spirit of friendly competition among employees is deeply rooted. These friendly rivalries advance innovation and spur the development and acquisition of new technology. Innovations made at plants are validated at the Karuizawa Plant, the mother plant, and quickly rolled out to all plants.

Though Minebea does not have a special technology achievement awards or honors program, the passion employees have for getting involved in research on new technology reflects a shared approach to manufacturing which transcends language and culture. When plants are constructed overseas, Japanese dispatched to support the new operations sweat it out alongside the local employees pushing mops and doing other chores, creating feelings of unity. This sense of being a part of the global "Team Minebea" generates unwavering bonds of trust among employees.

Uses of Ball Bearings

Ball bearings are used in a vast array of machines which support our daily lives. They can be found throughout society, from such household appliances as air conditioners and vacuum cleaners, to such vehicles as aircraft and automobiles, and such information communications equipment as personal computers and copy machines.

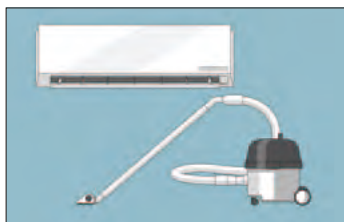

Household Appliances (air conditioners, vacuum cleaners, etc.)

The use of ball bearings helps to reduce friction within the machines and contribute to energy efficiency as well as reduce noise and support quiet operation.



Vehicles (automobiles, aircraft, etc.)

Long-life bearings contribute to the reliability of vehicles. A standard automobile has more than 100 bearings, requiring a variety of performance needs.

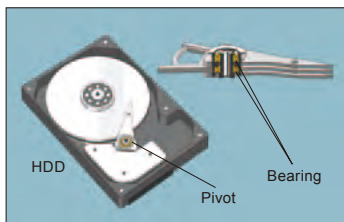

Information Communications Equipment (HDDs, copy machines, etc.)

As PCs become slimmer, the pivot used in HDDs (the bearing supporting the magnetic head actuator) has also needed to become slimmer, with a current thinness of about 1 millimeter.

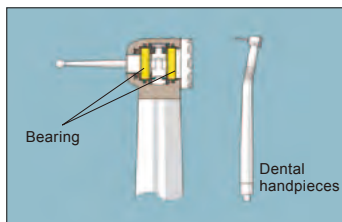

Other (dental handpieces, etc.)

Bearings are also used in a wide range of other places throughout society. For the handpieces used in dentist offices, the bearings must be able to support high-speed rotation and withstand rust and corrosion.

Continuing to Meet the Changing Demands of New Eras

Minebea's manufacturing approach has remained unchanged since the company's founding, even to the present day, when the company has risen to hold the world's No. 1 share in the miniature ball bearing market. That approach can be summarized as the provision of products and technology society needs, by optimal means—in the simplest terms, manufacturing higher quality products, at a lower price, faster, and in greater quantities than the competition. Amid changing eras, however, the demand for better bearings—which are often called the "backbone" of industry—never stops.

For example, Minebea has succeeded in enhancing the corrosion-resistance of bearings more than 20 times the traditional level to meet demands for products which can be used in healthcare-related equipment exposed to water, blood, and chemicals. We continue to research the miniaturization of HDD bearing width from 2mm to 1mm as notebook PCs reach the limit of thinness. As a further example, we continue to develop ball bearings for turbo chargers, which can reduce the environmental burden of automobiles, in order to meet demands for products which can operate stably under severely high temperatures and high rotational speeds.

At Minebea, we are acutely aware of the importance of our responsibility to supply products as a leading bearing manufacturer. In 2011, during the massive flooding in Thailand, some of our bearing manufacturing plants were idled for about two weeks. We responded by increasing production at manufacturing plants in other locations. In fact, even before this crisis, we had established a structure in which we strategically stock parts and products to ensure that we can continue to supply customers without delay even with a one-month suspension of manufacturing operations. This structure ensures that any crisis has a minimal affect on customers.

The 60-year history of Minebea since its founding has been a chronicle of simple and sincere manufacturing challenges. That history has nurtured a unique manufacturing philosophy which emphasizes manufacturing higher quality products, at a lower price, faster, and in greater quantities than the competition. This will remain the central credo by which Minebea contributes to society and fulfills its responsibilities into the future. Minebea will continue to take on new manufacturing challenges in order to respond to the needs of its customers, employees, local communities, and other stakeholders and meet society's expectations.



Developing CSR Together with Suppliers

The Minebea Group established its CSR Procurement Guidelines in 2012 in order to promote CSR in its procurement activities.

Exactly how should Minebea instill its CSR approach widely among suppliers and encourage them to put the approach into practice? Minebea held a dialogue with suppliers to discuss this very issue on April 26, 2012.

Introduction: Minebea's CSR Procurement Policy

Minebea (Mr. Imanaka): I would like to thank everyone for coming today. Two years ago, Minebea established the CSR Promotion Office and announced that it would heavily promote CSR as part of the our management policy. Today marks our first supplier dialogue and we look forward to receiving your forthright opinions about our CSR initiatives. Your remarks will support the overall promotion of CSR at Minebea and the development of our CSR procurement activities.



Mr. Masayuki Imanaka, Minebea

Minebea (Mr. Iwatani): First, I'd like to explain the Minebea Group's approach to CSR procurement.

No company can fulfill its social responsibility on its own. The same is true of CSR procurement. We must gain the understanding of our suppliers and carry out initiatives with their collaboration.

This is why we decided to establish the Minebea Group CSR Procurement Guidelines for our suppliers in 2012 on the basis of the Minebea Group Code of Conduct. The guidelines are comprised of 29 items grouped into the four sections of "Labor," "Health and Safety," "Environment," and "Ethics and Business Practice." Additionally, with regard to our Basic Procurement Policies, we have added "CSR Procurement" to supplement the five existing areas of "Compliance with Laws and Regulations," "Open Door Policy," "Equity and Fairness," "Green Procurement,"

and "Maintaining Confidentiality." Both the CSR Procurement Guidelines and the Basic Procurement Policies will be posted on our website between May and June, and we plan to distribute them to our domestic suppliers.

We also plan to create a CSR Self-Evaluation Check Sheet to promote self-evaluations among our suppliers. We plan to begin distributing this check sheet among suppliers in April 2013, and develop a firm grasp of the CSR status among suppliers by 2015.



Mr. Mamoru Iwatani, Minebea

Status of CSR Activities among Suppliers

Mr. Mizukami, CSR Consultant: I'd like to proceed with the dialogue by having each of the participating suppliers give an overview of their CSR activities.

Kyodo Yushi (Mr. Watanabe): As a grease and lubricants manufacturer, Kyodo Yushi aims to make a contribution to industry through the implementation of our spirit of Tribology (friction). This is the core of our social responsibility. We do not have a CSR framework, but we do operate the Tribology Study Group as a bridge between industry and academia, and we are promoting various initiatives in the areas of environmental management, energy-efficient products, employment of people with disabilities, and compliance.

Nichia (Mr. Akagi): At Nichia, our code of conduct promotes research, a thoughtful and industrious work

▶ Supplier Dialogue Participants

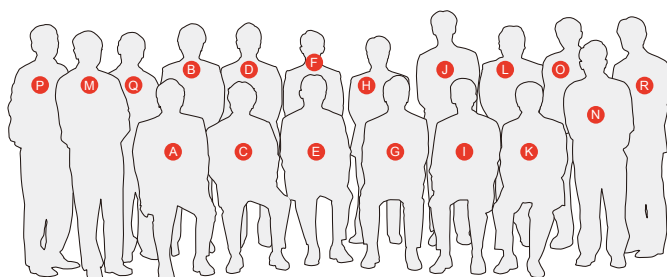

A	Kyodo Yushi Co., Ltd.	General Manager, Sales Department No. 1	Mr. Kazuhiko Watanabe
B	Kyodo Yushi Co., Ltd.	Supervisor, Sales Department No. 1	Mr. Yuji Ito
C	Sumitomo Metal Industries, Ltd.	Deputy General Manager, General Affairs Dept.	Mr. Ritsu Haga
D	Sumitomo Metal Industries, Ltd.	Manager, Export Section, Steel Sheet Sales Department	Mr. Tadashi Adachi
E	Nichia Corporation	Deputy Executive General Manager, Optoelectronics Production Division, Optoelectronics Products BU.	Mr. Masao Akagi
F	Nichia Corporation	Assistant Manager, Nagoya Sales Department, Optoelectronics Products BU.	Mr. Nobuyasu Kogure
G	Fujikura Ltd.	General Manager, Corporate Strategy Planning Division	Mr. Hideki Takimoto
H	Fujikura Ltd.	Assistant Manager, Electronics And Automotive, Global Marketing Department 1	Mr. Atsushi Wasa
I	Fuji Print Industrial Co. Ltd.	Director Business Headquarters Division	Mr. Noriyuki Tomita
J	Fuji Print Industrial Co. Ltd.	Assistant Manager, Sales Department No. 1, Business Headquarters	Mr. Mamoru Shimagami
K	Porite Corporation	Manager, General Affairs Dept., Head Office & Factory	Mr. Shinkichi Ooshima
L	Porite Corporation	Manager, Sales Department, Kumagaya Plant	Mr. Takeshi Hasegawa
M	Minebea Co., Ltd.	Managing Executive Officer, Officer in charge of Finance & Compliance Promotion Division	Mr. Masayuki Imanaka
N	Minebea Co., Ltd.	Managing Executive Officer, Officer in charge of Procurement & Logistics Division	Mr. Takashi Aiba
O	Minebea Co., Ltd.	Head of Procurement Department, Procurement & Logistics Division	Mr. Mamoru Iwatani
P	Minebea Co., Ltd.	General Manager, CSR Promotion Office	Mr. Masaki Ishikawa
Q	Minebea Co., Ltd.	CSR Promotion Office	Mr. Hideki Kobayashi
R	Cre-en Inc.	CSR Consultant	Mr. Takehiko Mizukami

ethic, and the creation of the world's best products. We have put great value on the continued creation of fine and elaborate products in Japan. One of our mottos is that companies which are not beloved by their suppliers will not endure. Based on that motto, we aim to expand together with collaborating companies and companies in our local community.

Porite (Mr. Ooshima): This year marks our 60th anniversary, and for the occasion we have established Employee Guiding Principles and a Porite Corporate Code of Conduct. Though we are making contributions to society through our business activities, there are human resource and financial limitations on what we can do in addition to that. We are expanding our business overseas and debating whether or not we can implement the principles and code of conduct at overseas offices. So, we have not yet disclosed them outside the company.

Fuji Print Industrial (Mr. Tomita):

In May 2011, we established a new corporate philosophy and we are fulfilling our social responsibility by executing the philosophy. We have set goals to achieve with each of our stakeholder groups, and we have a very strong awareness of the importance of communication. For example, we hold regular social events with our suppliers, and our 10 major suppliers are all shareholders in our company, making it possible for us to better reflect their views in our management.



Mr. Noriyuki Tomita,
Fuji Print Industrial

Mr. Mizukami: In order to achieve the goals you have set for each stakeholder group, have you established a CSR promotion committee or some other kind of organization to facilitate the activities?

Fuji Print Industrial (Mr. Tomita): We do not have any such organization. We do, however, hold a management policy conference at the start of each fiscal year at which the president, myself, and group managers explain the current year's CSR policies for each of their groups. Thereafter, we have monthly business conferences at which we report on the progress and outlook of measures. CSR is treated as one

management issue and we review CSR measures using the PDCA cycle approach.

Sumitomo Metal Industries (Mr. Haga): At Sumitomo Metal Industries, we established a CSR Committee in 2010 with the president as the committee chair. In March 2011, we established a Corporate Philosophy and revised the Code of Conduct. We are now working to instill these within the company and the entire group. Our aim is to enhance our value through technology, quality, service and CSR, and we will continue to take measures to become a company trusted by society.

Mr. Mizukami: Was there a particular occasion for establishing the committee?

Sumitomo Metal Industries (Mr. Haga): There was nothing particular. But in the General Affairs Department, we believed that despite the fact that we were taking various CSR initiatives, it was hard for people in and outside the company to see the whole picture behind our CSR effort, and we decided this was something we should do properly.

Fujikura (Mr. Takimoto): At Fujikura, we established a structure for CSR initiatives in 2009. A CSR Committee was established, headed by our president, and working teams on "management," "society," and "environment" were set up. Each business group sets new priorities every three years and information is shared between the groups and the initiative promotion teams in each division and group companies to ensure progress is made on the initiatives.

Mr. Mizukami: Was there a particular occasion for establishing the structure?

Fujikura (Mr. Takimoto): Each year we receive about 30 survey requests from our customers concerning our CSR initiatives. We felt that we could not respond without a proper structure in place. In that sense, there was recognition in the company that it was time for us to establish a structure and take full-fledged measures.

Minebea (Mr. Imanaka): Are there any full-time members of the committee?

Fujikura (Mr. Takimoto): There is a full-time member in the Global Environment Division. I manage initiatives in the areas of management and society.

Minebea's CSR Procurement Guidelines

Mr. Mizukami: Next, I'd like the participants to ask questions or make comments on the CSR Procurement Guidelines.

Nichia (Mr. Akagi): It is my understanding that broadly speaking, "Compliance with Laws and Regulations," "Equity and Fairness" and some other aspects of your Basic Procurement Policies could be considered part of CSR. In that sense, how are you positioning the new guidelines with respect to the existing policies?

Minebea (Mr. Iwatani): As you note, some of the areas of the new guidelines are covered by the pre-existing policies, but the new guidelines put a new focus on the four CSR areas of "Labor," "Health and Safety," "Environment," and "Ethics and Business Practice."



Mr. Shinkichi Ooshima, Porite

Porite (Mr. Ooshima): Speaking on behalf of my company, we will be able to comply with the contents of the new guidelines and we can confirm the compliance to a certain extent with regard to our primary suppliers. But regarding our secondary and tertiary suppliers, some areas of compliance may be difficult. I would like you to consider the level of the compliance required by your suppliers.

Fuji Print Industrial (Mr. Tomita): We also feel this is an issue, especially regarding small-sized suppliers. Even if they have a management structure in place, many of them do not have documentation and records. It will be difficult to have them submit reports to us, and that makes us wonder exactly how to proceed.

Minebea (Mr. Aiba): Actually, we have the same problem at Minebea. It's very difficult for us to confirm the activities of secondary and tertiary suppliers, and providing guidance is especially difficult with regard to overseas suppliers. But we can't give up. We are aiming to deepen understanding of the guidelines among our suppliers, even in small steps, and to move in the same direction with them. Then we can expect the understanding to gradually widen.

Nichia (Mr. Akagi): When confirming activities, it's important that making a plan and keeping a record are not the purpose of CSR initiatives, similar to some of their ISO activities, in order to prevent compliance with guidelines from becoming a superficial activity. It's important to have each supplier constantly consider where their activities are lacking and what initiatives they need to implement to prevent self-complacency.

Mr. Mizukami: We heard previously that Fujikura has made strong progress with CSR procurement activities, and I'd like to know how Fujikura handles secondary, tertiary, and overseas suppliers, which present the kind of problems we've just heard.

Fujikura (Mr. Takimoto): Previously, the operation conditions of one of our secondary Thai suppliers presented a problem from the perspective of CSR, and a local NPO conducted on-site research into the issue.

Dealing with this issue became the impetus for my company to take full-fledged CSR procurement measures. We wondered whether we should be requesting our suppliers to take certain measures when we were not taking thorough measures ourselves, but in the end we decided that we needed to define a basic position and request our suppliers to meet certain requests. If we didn't, then nothing would change.



Mr. Hideki Takimoto, Fujikura

First, therefore, we conducted a CSR procurement survey of all of our domestic suppliers in 2010. We had planned to conduct a similar survey of overseas suppliers in 2011, but we canceled the plan due to the Thai flooding damage. The structure is in place, so we will restart the initiative when circumstances are right.

Minebea (Mr. Kobayashi): How many suppliers in and outside Japan are part of your survey?

Fujikura (Mr. Takimoto): There are about 500 domestic suppliers. Outside Japan, we plan to conduct the survey at different levels, with about 300 companies at the primary level.

Mr. Mizukami: What were the results of the domestic survey?

Fujikura (Mr. Takimoto): Of course, there were many suppliers who were very highly rated by the survey, but honestly speaking, there were many who fell short of our expectations. For those suppliers, we held follow-up meetings, and in some cases, we will visit them directly.

Minebea (Mr. Imanaka): It appears that surveys are very important. Sending out the survey provides an opportunity for the suppliers receiving them to think about CSR procurement. We also believe that a survey is the best way to begin the process, including for overseas suppliers.

Expectations of Minebea

Mr. Mizukami: I'd like to hear participants' comments on what they expect of Minebea in terms of support for carrying out CSR procurement in line with the guidelines.

Porite (Mr. Ooshima): In regard to chemical substance regulations, for example, there are instances when it is difficult to ask small suppliers for an official product certificate. We would like some guidance on what kind of certificates would be acceptable from small suppliers. We would also like some guidance on exactly how to give advice to suppliers in order to have them smoothly comply with our requests.

Kyodo Yushi (Mr. Watanabe): Especially with overseas suppliers, we'd like Minebea to understand that many suppliers say they cannot disclose information regarding the use of chemical substances. In addition, when we are required to submit quantitative



Supplier dialogue

data, please consider the fact that chemical substance analysis and other fees are incurred.

Fuji Print Industrial (Mr. Tomita): I feel that just having these types of opportunities to meet face to face with you will make it significantly easier to carry out initiatives in the future. For us as well, while it may be impossible for all suppliers to comply with our requests, we would like to start by having these types of meetings with a select number of suppliers and then gradually expand efforts to our entire supply chain. We would like to use these human connections to make progress on CSR procurement.



Mr. Kazuhiko Watanabe,
Kyodo Yushi

Fujikura (Mr. Takimoto): One of the advantages of listening to the activities of companies with advanced CSR activities is that we can see, among all the possible initiatives, which ones we need to prioritize. That's why this type of dialogue today is so important.



Mr. Masao Akagi,
Nichia

Nichia (Mr. Akagi): As we've heard from the discussion today, requests from outside your company can become significant opportunities to move your company in the right direction, so by all means I'd like Minebea to conduct its survey. For Nichia, we've always prided ourselves on domestic manufacturing, and consequently there are areas of doing business overseas which we have little knowledge of or experience with. We would appreciate any guidance from Minebea on expanding CSR outside Japan.

Sumitomo Metal Industries (Mr. Haga): With regard to your survey, I would like Minebea to share the results with all the companies that participate. Receiving feedback which shows that our efforts are lacking in certain areas compared to other companies will provide a strong motivation for promoting CSR procurement within my company.



Mr. Ritsu Haga,
Sumitomo Metal Industries

Mr. Mizukami: The comments from each of the companies here today reflect the importance of communication between companies and their customers and suppliers. I understand that Sumitomo Metal Industries' approach is to work together with each of its stakeholders and that you invest a lot of

energy in this.

Sumitomo Metal Industries (Mr. Haga): We pursue improvements in compliance, safety management, quality management and other areas by working closely as one team with partner companies. Our thinking is that we can help each other raise the level of activities by collaborating in the same places and on the same kinds of activities.

We regularly dispatch veteran employees from our steel mills to customer sites where our products are actually being used to verify that the products meet our quality standards. Customer feedback is then routed back to the steel mills as part of our quality assurance cycle.

Conclusion: Exactly What Is CSR Procurement?

Mr. Mizukami: CSR can be defined as activities a company takes to earn the trust of its stakeholders, and primarily the assurance that its business activities will not be a detriment to society. In recent years, there has emerged a shared global awareness of the need for companies to exert influence over their supply chains as part of their CSR activities. CSR procurement is essentially working with customers and suppliers to ensure that the entire supply chain does not have a detrimental effect on society. Today's discussion reaffirmed the importance of building mutually beneficial relations with customers and suppliers and creating value for society out of the entire supply chain.

Finally, I would like to conclude the discussion with comments from Minebea on the promotion of CSR procurement.

Minebea (Mr. Aiba): The valuable views and suggestions that we have received today will be reflected in our manufacturing and procurement activities going forward as we aim to make even greater strides together with you. In particular, procurement issues surrounding rare earth elements are in the spotlight, and I look forward to working with everyone to address the issues while assiduously fulfilling our social responsibilities. Thank you very much for taking part in today's dialogue.



Mr. Takashi Aiba,
Minebea



Minebea Group CSR

Basic Approach

The Minebea Group believes that enterprises have a mission to contribute to the sustainable development of the global environment and of humanity, not only through strict adherence to laws and regulations, but also through fair and proper management of our business in accordance with business ethics. To fulfill this mission, The Minebea Group established the Five Principles. On the basis of the Five Principles, the Minebea Group Basic CSR Policy and the Minebea Group's CSR Implementation Principles were established as platforms for promoting CSR initiatives.

Minebea Group Stakeholders

The Five Principles focus on employees, customers, shareholders, local communities, global society, suppliers, and the environment that supports our society. The Minebea Group considers each of these groups to be separate stakeholders. In carrying out CSR activities, the Group believes that it is essential to maintain communication with each stakeholder group and meet their expectations.

The Five Principles

- ⊙ Be a company where our employees are proud to work
- ⊙ Earn and preserve the trust of our valued customers
- ⊙ Respond to our shareholders' expectations
- ⊙ Work in harmony with the local community
- ⊙ Promote and contribute to global society

Minebea Group Basic CSR Policy

As a manufacturer of precision products supporting society, the Minebea Group is working toward stable supply and making reliable products with low energy consumption widely available, to contribute to the sustainable development of the global environment and of humanity.

The Minebea Group's CSR Implementation Principles

1 The Five Principles and our Code of Conduct

In promoting CSR activities, the Minebea Group will appropriately manage the organization in accordance with the Five Principles, and adhere to its Code of Conduct.

2 Continuous improvement and raising of awareness

We will put forth goals to be achieved, based on understanding the Minebea Group's social responsibilities and the key problems that need to be addressed, and continue to improve our CSR activities through implementation and continual review. We will also strive to raise awareness of CSR among all employees through CSR activities.

3 Dialogue with stakeholders

Constructive dialogue with stakeholders (employees, customers, shareholders, local communities, global society, suppliers, and the environment) allows us to meet expectations and respond to requests, and we will improve transparency and accountability in our corporate activities.

Minebea Group Stakeholders



Corporate Governance



Basic Approach

Under its basic management policy of the Five Principles, the Minebea Group's management objective is to fulfill its social responsibilities to its diverse stakeholders, and to maximize its corporate value. To achieve this management objective, Minebea regards the enhancement and reinforcement of corporate governance as a key management theme.

Corporate Governance System

Minebea maintains a ten-member Board of Directors to meet our need for high-level strategic business judgments and prompt action. At the same time, our executive officer system enables the Board of Directors to delegate significant responsibility, and clearly divides management and supervision functions from executive functions.

Moreover, our ten-member Board of Directors includes two external members who provide advice on all aspects of our corporate management. These external members also strengthen the Board's oversight function relating to the conduct of our business.

Furthermore, for a stronger, comprehensive auditing function, three of our four corporate auditors are external auditors (one of whom is a standing auditor).

In addition to conducting Board of Auditors meetings and attending Board of Directors and other important meetings, the corporate auditors, in conjunction with independent auditors and the Internal Auditing Office, conduct audits of domestic offices, subsidiaries, and overseas subsidiaries as well as auditing the activities of directors.

● Supervision of Management

Minebea's supervision of management is performed by our ten-member Board of Directors, whose responsibility it is to make critical strategic business judgments in a timely manner. The Board of Directors includes two external members who provide advice on all aspects of our corporate management. These external members also strengthen the Board's oversight function relating to the conduct of our business.

● Management Execution Function

Minebea employs an Executive Officer system to delegate the management authority of the Board of Directors to Executive Officers, and promote responsive, timely, enhanced management.

● Management Monitoring System

Minebea has adopted a management monitoring system consisting of four corporate auditors, of whom three are external auditors.

In addition, members of the Minebea Board of Directors do not have titles. This is intended to enhance overall monitoring of board members.

Enhancement of Internal Control System

Minebea's Board of Directors makes decisions on basic policies for the internal control systems in order to implement specific measures to ensure the soundness of management. On the basis of this approach, the Group has established a Compliance System, Information Storage System, Risk Management System, System for an Efficient Execution of Duties, System for the Management of Group Companies, and various other auditing structures. The Group is striving to bolster all of these systems.

▶ Internal Control System Structure

- 1 Structure to assure that the execution of duties by board members, executive officers and employees are in conformance with the law and Minebea's articles of incorporation (Compliance System)
- 2 Storage and management of information related to execution of duties by board members and executive officers (Information Storage System)
- 3 Rules for managing loss risk and other rule structures (Risk Management System)
- 4 Structure to assure efficient execution of duties by board members and executive officers (System for an Efficient Execution of Duties)
- 5 Structures to ensure that the operations of the company and its affiliates are appropriate (Management of Group Companies)
- 6 Structures to ensure that audits by the Corporate Auditors are effective (Audit System Matters)

Internal Controls over Financial Reporting

To ensure the reliability of its financial reporting, Minebea has established internal control structures and systems which are improved on a continual basis. Regarding internal controls over financial reporting required by Japan's Financial Instruments and Exchange Law, the Group has striven to comply with the law in its basic internal control framework and establish and operate controls appropriately.

Management assesses the status of the establishment and operation of internal controls, and as of March 31, 2012, management had determined that the Minebea Group's internal controls over financial reporting were effective. In addition, as required by the Financial Instruments and Exchange Law, Minebea reported on the results of this assessment in its Report on Internal Control Systems and submitted the report to its auditor, KPMG AZSA LLC, which audited the report and concluded that the contents demonstrates that Minebea was operating in conformity with the aforementioned law.

For further details on the Minebea Group's corporate governance system, please visit the corporate website:
http://www.minebea.co.jp/english/company/aboutus/governance/policy_system/index.html

Compliance



Basic Approach and System for Promoting Compliance

The Minebea Group regards compliance as an indispensable factor in our business activities. We believe compliance not only involves adherence to laws and regulations but also involves activities in accordance with corporate ethics as a good corporate citizen, based on an awareness that putting compliance into practice is one element of CSR implementation. To this end, we have prescribed the Minebea Group Code of Conduct and Minebea Group Officer and Employee Compliance Guidelines as a set of standards for group executives and employees in selecting appropriate actions and striving to conduct our business in a fair, proper, and transparent manner.

The President and Chief Executive Officer of the Minebea Group has overall compliance responsibility, supported directly by the Compliance Committee. The Compliance Committee is responsible for applying the Code of Conduct, and for decision-making regarding emergency measures in the event of significant violations of the code. The Compliance Office of the Corporate Finance & Compliance Promotion Division acts as the secretariat for the Compliance Committee, carrying out education, training, and other measures to promote compliance throughout the company.

Compliance Education

To help employees understand compliance, the Minebea Group conducts compliance education as part of its training programs for employees at each rank. In FY2011, 224 employees received training, comprised of new employee training and training for new managers and assistant managers. During the year the Group also strengthened compliance awareness through a DVD-based video training program taken by 2,641 employees.

In recent years, stronger compliance management has become a carefully watched public issue amid a spate of corporate scandals. In response, the Group held compliance training for 33 executive officers including the president. An outside attorney was invited to conduct the training session.



New employee training

To teach employees about insider trading rules prescribed by the Financial Instruments and Exchange Law, an easy-to-understand e-learning program was also rolled out and taken by 967 employees.

Internal Reporting System

To prevent actions in violation of the Minebea Group Code of Conduct or legal infractions, we have established internal as well as external consultation centers that employees can access when they are unsure as to whether or not an action or decision on their part may be in violation of the Code of Conduct, or if they encounter actions on the part of others that may be in violation of the Code.

Import/Export Control Initiatives

The Logistics Division is primarily in charge of import and export matters for the Minebea Group. The division creates procedural manuals and guides for adhering to the Customs Law and other regulations and provides a management structure to ensure compliance. In FY2007, we received Authorized Importer and Authorized Exporter certification from Tokyo Customs in recognition of our outstanding freight and compliance management.

Future Compliance Promotion

The Minebea Group believes that employee awareness and knowledge of compliance should be deepened to establish a corporate culture in which each employee maintains an awareness of compliance in conducting business activities. Going forward, we will strengthen the Minebea Group's overall structure for compliance promotion, including for overseas subsidiaries, and will continue working to implement more efficient and effective compliance-related educational activities.

The Group will also continue to implement training on legislation such as antitrust laws, striving to prevent violations before they occur.

For further details on the Minebea Group Code of Conduct and the Minebea Group Officer and Employee Compliance Guidelines, please see the Minebea Group website. (<http://www.minebea.co.jp/english/company/aboutus/conduct/declaration/index.html>)

Risk Management



Basic Approach

Because our response to risk could profoundly affect the Minebea Group's business fundamentals, we believe that risk management is vital to the management of the company. We established the Minebea Group Basic Rules for Risk Management which define preventive measures we should have in place, our response in crisis situations, and the type of system the group should put in place.

Risk Management System

The President and Chief Executive Officer of the Minebea Group has final responsibility for risk management, with major decisions regarding risk management being made by the Risk Management Committee. As a precautionary measure, Minebea attempts to predict and classify tangible risks in advance, and remains vigilant against such risks. In the unlikely event of an emergency, the severity of the situation is assigned a level of one to three, and after consultation by the Risk Management Committee, management headquarters and local countermeasures offices are established, to respond rapidly and effectively to the situation. Further, Minebea has organized a system under which—depending on the nature of the risk being managed—a supervisory division may be appointed to handle a situation for which it will draft and implement responses.

In FY2011, in response to the Thai floods, the Group established a Management Headquarters (Meguro) which carried out close information sharing with the Local Countermeasures Office in order to handle customer inquiries and other response activities (please see P. 5 for detailed information on the response to Thai floods).

Information Security

Information Security Structure

The Minebea Group believes that protecting information assets is essential for building a relationship of trust. We have therefore established the Minebea and Minebea Group Basic Policy for Protection of Confidential Information (Information Security Basic Policy), which we thoroughly implement.

We have also established an Information Security Committee headed by a managing executive officer, composed of Information Security Task Forces that implement measures in each country.

Information Security Training

To improve employee awareness of information security, the Minebea Group conducts information

security training. Information security briefings are held annually, and tutorials are conducted by the Information Security Task Force in addition to training for new and experienced employees when they enter the company. Information security briefings were conducted from March through July 2012, and 10,326 employees participated, including temporary staff and subcontracted employees.

Going forward, our training will help employees to enhance their awareness of information security violations and share information on such matters as the kinds of things that can lead to security violations.

Initiatives to Protect Personal Information

Personal information retained by the Minebea Group is managed in accordance with our Personal Information Protection Policy. The purposes for which this information is utilized have also been clearly defined, and we strictly adhere to the parameters for scope of information use.

BCP Initiatives

The Minebea Group will ensure the safety of its employees and their families in the event of a widespread disaster, influenza, terrorist acts or other emergencies. To deal with such eventualities, we have created the Minebea Group Basic Rules for Risk Management, to meet our responsibilities to our customers as the component manufacturer with the world's largest market share, and to keep disruption of our business to a minimum. Specifically, we have created an emergency manual, reinforced our plants against earthquakes, stored emergency food supplies, and adopted a system to confirm the safety of our personnel.

BCP Formulation Seminar

In FY2011 and FY2012, the Minebea Group held seminars on BCP (Business Continuity Plan) formulation at the Karuizawa Plant and the Hamamatsu Plant. At each plant, 180 employees took part in the seminars to understand the fundamentals of BCP and for a practical lesson in formulating BCPs for their own work sites.

Formulating a BCP for the Entire Group

The Minebea Group is strengthening its risk management system. Comments and ideas received from employees during the FY2011 and FY2012 BCP formulation seminars have been integrated into the Group's own BCP, and in FY2012 work on the establishment and operation of a BCP for the entire Group was started with the goal of having the plan thoroughly instilled throughout the Group.



CSR Promotion Activity Goals and Results

► Results for FY2011 and Goals for FY2012 and the Medium Term

		FY2011 Goals	FY2011 Results
Management	CSR management	Build a structure for promoting a PDCA system for CSR management CSR	Established an interdivisional CSR working group to share progress on CSR goals
		Promote stakeholder engagement CSR	Held a stakeholder dialogue with suppliers
		Promote internal CSR dissemination initiatives CSR	Distributed an internal message from the president to coincide with publication of FY2011 CSR Report, and introduced the Group's CSR approach and activities in the internal company magazine
	Corporate governance Compliance Risk management	Strengthen compliance system on a global basis Compliance	Expanded scope of compliance consultation center to inquire from Japanese employees assigned to overseas sites
		Continuously implement compliance training and introduction of e-learning Compliance	Continued to provide training for employees at each rank and provided a DVD video training program at each site for all employees not covered by the rank-based training; introduced an e-learning program
		Promote BCP formulation Personnel & GA	Assigned a BCP manager at each domestic site/division and held BCP formulation seminar for managers
	Strengthen disaster mitigation system at domestic sites Personnel & GA	Established a disaster response headquarters, manuals, safety confirmation system, early earthquake notification system and emergency food and other necessities for disasters	
Society	Relationships with customers	Strengthen significant quality issue response and review system Quality Management	Published "Detailed Rules for Internal Procedures upon Occurrence of Significant Quality Issue" and clarified implementation of reviews to prevent reoccurrence
		Formulate recall handbook in accordance with Product Safety Guidelines Quality Management	Formulated recall handbook in accordance with Product Safety Guidelines
		Promote acquisition of international Quality Management System (QMS) certification to strengthen Quality Assurance System Quality Management	Acquired ISO 13485 certification for EMS Business Unit
		Promote acquisition of Authorized Economic Operator (AEO) (advanced qualification) status in South Korea and Singapore Logistics	Promoted acquisition of AEO status in South Korea and Secure Trade Partnership (STP) – Plus in Singapore (similar to Korea's AEO)
		Promote bar code-based product management to prevent such issues as incorrect shipments Logistics	Promoted bar code-based product management for PM motors and fan motors
	Relationships with employees	Strengthen human rights education Personnel & GA	Implemented human rights education through compliance training and provided anti-harassment education during new assignment training
		Strengthen development and utilization of personnel suited for global development Personnel & GA	Held a global human resources and general affairs meeting to share training systems, promote training prior to international assignments, and strengthen international assignment rotations
		Promote initiatives relating to work-life balance Personnel & GA	Promoted work-life balance awareness through internal magazine and provided training to female employees at headquarters to expand the active roles of female employees
	Relationships with local communities and global society	Meet legally required employment percentages for the handicapped and support for their employment Personnel & GA	1.91% of the workforce was handicapped; ongoing support was provided to handicapped employees through mentoring system
		Initiate formulation of a Social Initiative Policy for the Minebea Group CSR	Revised basic approach to making social contributions primarily in response to the needs of local communities, based on the Minebea Group Code of Conduct
	Relationships with suppliers	Conduct training relating to the Act against Delay in Payment of Subcontract Proceeds, Etc. to Subcontractors, and implement self-auditing relating to the Act Procurement	Conducted training at headquarters and domestic sites relating to the Act against Delay in Payment of Subcontract Proceeds, Etc. to Subcontractors (217 participants), and implemented self-auditing (five sites, six times)
		Establish CSR procurement framework Procurement	Established CSR Procurement Guidelines based on Minebea Group Code of Conduct
Relationships with shareholders	Promote active information disclosure relating to progress and implementation of Medium-term Business Plan IR	Promoted disclosure of Medium-term Business Plan through general shareholders' meeting, semiannual business report, website information, etc.	
	Promote active communication with domestic and international investors IR	Held four briefings on financial results and conference calls for institutional investors and securities analysts and one tour of visits to investors in the U.S., Europe, and Asia	
The Environment	Environmental management	Acquire ISO 14001 certification (Yonago Plant, etc.) Environment	Acquired ISO 14001 certification for Yonago Plant and Daiichi Seimitsu Sangyo Co., Ltd.'s China plant
		Review of Environmental Philosophy Environment	Reformulated Environmental Vision into the Environmental Policy and revised contents with new proposals
	Initiatives for preventing global warming	Establish Minebea Group medium- and long-term targets for reducing CO ₂ emission volume Environment	Set a target of reducing CO ₂ emissions per basic unit of output by 1% each year, for 5% reduction by FY2015 compared with FY2010
		Reduce CO ₂ emission volume for Minebea Group plants worldwide (establish base year, specify overall volume and reference unit) Environment	Reduced CO ₂ emissions by 3,069 tons, but emissions per basic unit of output rose 6.3%
		Ascertain CO ₂ emission volume for overall Minebea Group distribution Logistics	Ascertain CO ₂ emissions for Japan logistics and overseas air and sea logistics
	Initiatives for effective use of resources	Promote use of proper transport measures to reduce energy consumption Logistics	Transport of fan motors in South China partially shifted from ship and air transport to rail transport
		Reduce volume of waste ultimately disposed of as landfill by Minebea Group plants worldwide to less than 4,000 tons per year Environment	Landfill waste from worldwide Minebea Group plants totaled 4,061 tons
		Define Minebea zero emissions, investigate current status Environment	Researched status of zero emissions at Minebea and other companies and defined zero emissions for Minebea
	Initiatives for Reducing Impacts on the Environment	Reduce plant effluent volume Environment	Reduced plant effluent volume by 235,000 tons
		Investigate/implement returnable package system for international shipping Logistics	Made preparations to implement returnable package system for truck shipments between Thailand and Cambodia to supplement existing one-way shipments from Thai sites to customers
		Zero violation of environmental laws and self-imposed regulations Environment	Zero violation of environmental laws and self-imposed regulations
		Complete cleanup measures at plants where soil and groundwater pollution has been confirmed (Ichinoseki Plant) Environment	Completed cleanup of soil and groundwater pollution at Ichinoseki Plant
		Manage volumes of chemical substances used at Minebea Group plants Environment	Established new chemical substance application database to efficiently manage chemical substances
	Product-related Initiatives for the Environment	100% implementation of Pollution Patrol Programs Environment	Achieved 100% implementation of Pollution Patrol Programs
		Implement regular local audits of waste disposal companies Environment	Implemented regular local audits of waste disposal companies
Establish criteria for Minebea green products (environmentally conscious products) Environment		Established selection criteria for Minebea green products	
	Develop products and technology contributing to energy efficiency, resource efficiency, and waste reduction Environment	Developed lightweight bearings and other products which do not require lubricants	

CSR Promotion Activity Goals and Results

The Minebea Group believes it is important to manage CSR activities appropriately using the Plan-Do-Check-Action (PDCA) cycle and sets CSR goals accordingly.

Furthermore, to ensure that CSR activities are promoted in a planned fashion, the Group has established medium-term goals to be achieved by FY2015.

	Evaluation	FY2012 Goals	Medium-term Goals (target year of FY2015)
	○		
	○	<ul style="list-style-type: none"> Continue to promote PDCA management for CSR activities CSR Continue to promote internal awareness activities for CSR CSR 	<ul style="list-style-type: none"> Promote CSR management across the Group, including overseas sites CSR Enhance PDCA management to meet global standards CSR Promote CSR awareness activities across the Group, including overseas sites CSR
	○	<ul style="list-style-type: none"> Continue to bolster compliance system for domestic and overseas sites Compliance Reinforce overseas training Compliance Formulate BCP for domestic and overseas sites and begin their operation Personnel & GA Continue to strengthen disaster mitigation system at domestic plants Personnel & GA Strengthen risk management system for Thai floods Personnel & GA 	<ul style="list-style-type: none"> Establish a global compliance system Compliance Formulate a BCP for the entire Minebea Group and instill it through training Personnel & GA
	○	<ul style="list-style-type: none"> Revise the Quality Management Manual and clarify the implementation of risk assessment as the design and product manufacturing stages to bolster product safety Quality Management Create framework to promote acquisition of international Quality Management System (QMS) certification covering design and manufacturing in order to strengthen Quality Assurance System Quality Management Acquire STP-Plus certification in Singapore and prepare for certification in South Korea and the EU Logistics 	<ul style="list-style-type: none"> Create product safety assessment structure for product life cycle stages Quality Management Promote bar-coding for all products Logistics
	○	<ul style="list-style-type: none"> Continue to strengthen human rights education Personnel & GA Strengthen development and utilization of personnel suited for global development Personnel & GA Continue to promote initiatives relating to work-life balance Personnel & GA Meet legally required employment percentages for the handicapped and support for their employment Personnel & GA 	<ul style="list-style-type: none"> Strengthen the development of human resources in order to support the active expansion and development of global business Personnel & GA Proactively incorporate demands of society and promote measures to support employee motivation Personnel & GA
	○	<ul style="list-style-type: none"> Hold dialogues with local communities at domestic locations to better understand local needs CSR 	<ul style="list-style-type: none"> Hold dialogues with communities through sites in and outside Japan to expand social contribution activities based on understanding of their needs CSR
	○	<ul style="list-style-type: none"> Hold stakeholder dialogues with suppliers Procurement Promote CSR procurement by adding CSR requirements to Basic Purchasing Policy, publishing CSR Procurement Guidelines, creating CSR self-evaluation checklist, etc. Procurement 	<ul style="list-style-type: none"> Promote CSR procurement among domestic suppliers using CSR self-evaluation checklist Procurement Expand CSR procurement to overseas suppliers Procurement
	○	<ul style="list-style-type: none"> Continue to promote active information disclosure relating to progress and implementation of Medium-term Business Plan IR Continue to promote active communication with domestic and international investors IR 	<ul style="list-style-type: none"> Continue to actively disclose information and promote communication among a wider group of shareholders and investors to deepen their understanding of Minebea IR
	○		
	△		
	○		
	×		
	○	<ul style="list-style-type: none"> Acquire ISO 14001 certification (Suzhou Plant, Daiichi Seimitsu Sangyo Co., Ltd. head office) and prepare to acquire certification at other sites (Minebea Tokyo headquarters and Cambodia Plant) Environment 	
	○	<ul style="list-style-type: none"> Revise environmental policy Environment 	
	×	<ul style="list-style-type: none"> Reduce CO₂ emissions per basic unit of output by 2% compared with FY2010 Environment 	<ul style="list-style-type: none"> Reduce CO₂ emissions per basic unit of output by 5% compared with FY2010 Environment
	△	<ul style="list-style-type: none"> Establish systems and overall scheme to enable regular reporting of CO₂ emissions of overall Group logistics operations Logistics 	<ul style="list-style-type: none"> Expand improvements to packaging Logistics
	○	<ul style="list-style-type: none"> Improve packaging to raise logistics efficiency and reduce CO₂ emissions Logistics 	<ul style="list-style-type: none"> Greatly reduce landfill waste Environment
	△	<ul style="list-style-type: none"> Reduce Minebea Group plants' total landfill waste to under 4,000 tons/year Environment 	
	○	<ul style="list-style-type: none"> Begin operation of new chemical substance application database Environment 	
	○	<ul style="list-style-type: none"> Establish selection criteria for Minebea green products Environment 	
	○		
	○		
	△		
	○		

CSR CSR Promotion Office **Compliance** Compliance Office **Quality Management** Quality Management Support Office
Logistics Logistics Department **Personnel & GA** Personnel & General Affairs Department **Procurement** Procurement Department
IR Investors Relations Office **Environment** Group Environment Management Department

Commitment from the President

Floods in Thailand

Minebea Products in Society

Special Feature

Management Report

Social Report

Environmental Report



● Responding to the Quality Control Examination

The Minebea Group believes that improving the quality control and quality enhancement ability of individual employees ultimately leads to improving the quality of the Minebea Group. Since September 2008, we have been encouraging employees to sit for the quality control examination (QC examination) conducted by the Japanese Standards Association (JSA) and Union of Japanese Scientists and Engineers (JUSE). In addition to covering employees' course fees, we distribute textbooks to improve their knowledge of quality management. There were 110 employees who sat for the examination in FY2011, 85 of whom passed. A total of 274 Minebea Group employees have passed the examination so far.

● Thai Quality Improvement Teams Training

In FY2011, six representatives of the Thai business units participated in quality improvement team training as a way to further enhance product quality. The two-week training program at the Hamamatsu Plant included lectures on quality assurance and practical training on approaches to quality issue resolution.



Employees taking part in a training session

● Acquiring AEO Certification

The Minebea Group is strengthening and improving logistics management in order to perform trade and logistics properly and efficiently. As part of this initiative, the Group has begun taking measures to acquire Authorized Economic Operator (AEO) certification in Singapore, South Korea, and the EU. The Group is on track to acquire certification in Singapore by the end of FY2012.

● Bar Code Management to Prevent Mistaken Shipments

The Minebea Group's logistics management system uses bar coding to prevent the mistaken shipment of products. Bearing products, for example, are inspected upon storage or retrieval from inventory at all the global sales warehouses. At this time, the model and specifications of all products must be verified by bar code. From FY2011, the Group also started bar code management of PM motor products and preparations have begun for bar coding of fan motor products.

Disclosure of Product-related Information

Most products from the Minebea Group are ultimately integrated into finished products that pass into consumers' hands. For this reason, we provide safety related information to our customers as requested. Also in response to customer requests, we provide information about chemical substances incorporated in our products, based on information obtained from suppliers.

For speakers, keyboards and some other finished products, user manuals include safety-related information.

Communication with Customers

● Customer Satisfaction Surveys

Within the Minebea Group, individual business units conduct their own customer satisfaction surveys. This research spans a comprehensive range of evaluation criteria, including sales support, response to product related problems, and product prices. Findings based on these data are fed back to the sales and development departments of the corresponding business units. If customers should evaluate any criterion below a specific satisfaction level, we assess and implement improvements across all business units.

Responding to Quality-related Problems

If a serious problem concerning the quality of Minebea Group products or services were to occur, the optimal response would be determined based on the Quality Management control rules.

In FY2011, detailed rules on internal procedures for handling significant quality issues were created to clarify internal procedures for handling major quality issues. Additionally, business units have drawn up recall guidelines for keyboards and other products supplied directly to consumers.

Future Issues and Goals

The Minebea Group is creating procedural manuals and strengthening its structure for assessment in order to ensure product safety at every stage of the product lifecycle. The Group will also continue to pursue quality management certification.

In logistics operations, the Group is promoting the acquisition of AEO certification and bar code management for all of its products.

Relationships with Employees

Basic Approach

Since its founding, the Minebea Group has recognized that employees are its most valuable resource, and one of our Five Principles is that the company should become a place where its employees are proud to work. The Minebea Group is committed to maintaining and improving workplaces where each of our employees can work safely and in good health, and fully exercise his or her abilities.

Minebea Group Workforce

(as of March 2012)

	Employees			Japanese staff on overseas assignment	Total
	Male	Female	Total		
Japan	2,796	572	3,368	0	3,368
North America	1,138	758	1,896	22	1,918
Europe	674	358	1,032	25	1,057
Asia	10,767	33,885	44,652	411	45,063
Total	15,375	35,573	50,948	458	51,406

Human Resources Development

The Minebea Group seeks employees who can work on the global stage, have the independence to develop their own ideas, and welcome challenges, and we work to provide education that encourages those qualities. We have specially tailored programs for every employee rank, including new and intermediate-level employees and newly-appointed managers, and we conduct training programs and on-the-job education to enable employees to acquire specialized knowledge and strengthen their skills.

Principal Domestic Training Programs by Rank (FY2011)

Program	Participants	Aim of Training
New Employee Training	New employees	<ul style="list-style-type: none"> Learn the proper manners expected of working members of society, attitudes toward work, and how to carry out work duties. Understand the company's management philosophy and code of conduct, and company rules, systems, and organization.
Junior Employee Training	Employees in their second year of employment	<ul style="list-style-type: none"> Learn goal setting and ensure ongoing personal development. Learn fundamentals for improving performance and the basics and importance of communication.
Intermediate Level Training I	Employees in around their fifth year of employment	<ul style="list-style-type: none"> Review personal abilities and future goals, and consider how to proceed going forward. Understand the role expected of them at their work site and learn to be self-reliant in their environment.
Intermediate Level Training II	Employees in around their 10th year of employment	<ul style="list-style-type: none"> Raise the value (quality) of their work by reevaluating the meaning and value of their work and the company from the perspective of the customers and the market.
New Assistant Manager Training	Newly promoted assistant managers	<ul style="list-style-type: none"> Understand the role expected of assistant managers as supervisors. From their perspective as work site leaders, develop the ability to solve the problems of their work site by engaging others.
New Manager Training	Newly promoted managers	<ul style="list-style-type: none"> Learn the fundamentals of management reform; study the approaches and methods to solving their divisions' problems by thinking about the problems laterally across many divisions and from a management perspective.

*Note: In addition to the above, a manager training program and a training program for intermediate-level employees are held every two years for Japanese employees on overseas assignments.

Brother-Sister System

A Brother-Sister System was introduced for employees of Minebea Group's domestic sales division on an experimental basis in April 2010, and full-fledged implementation of the system began in FY2011. Under this system, a young employee takes on the role of mentor for a new employee. In addition to teaching business skills, the program supports relationship building so new employees can feel free to consult their mentors concerning non-work issues, and develop their independence. In FY2011, 12 new employees took part in this system.

Using the Brother-Sister System

I found there to be big advantages to this system. When I was assigned to my division, I didn't know anyone and felt very apprehensive. But having a senior employee around my age assigned to me as a brother really helped me to build relations with people inside and outside the company.



Shigeki Endo
BA Sales Division
Domestic Sales Division

I had no experience, but my brother cared a lot about helping me get to the point where I could do my own work. There were private occasions when we went drinking together and I could consult with him about small problems and such. This was very supportive.

This year I will probably take on the role of a brother for a younger employee. I'd like to share my experience and the benefits of this system with others.



● **Global Human Resources Development**

To promote its global human resources, the Minebea Group is committed to broadening the playing field for employees.

We want more employees to have an opportunity to engage in global activities, so if stationed overseas they can stay for a maximum of five years according to established guidelines.

To nurture our global staff, we also provide manager training opportunities for Japanese assigned to overseas subsidiaries based on the Japanese training program, as well as opportunities for local overseas staff to train for management positions under their subsidiaries' programs.

● **Global HR Meeting**

In July 2011, the Minebea Group held a global human resources meeting which gathered HR managers from throughout Asia (Thailand, Shanghai, Zhuhai, Singapore, and Malaysia). The meeting provided an opportunity to share information on labor issues, employee development, and hiring. In the future, such meetings will be held regularly and successful initiatives will be shared laterally across the Group.

■ **Experiencing an Overseas Assignment**

After entering the company, I worked for three years in the Karuizawa Plant's fan motor business unit before being assigned to NMB-Minebea-GmbH for about 10 months.

Of course, the customers and the language in Germany are different from those in Japan, but there are also different demands with regard to the product compared to the Japanese market.

It would be difficult to understand the differences in the market environment without actually being there in Germany. I learned that we must provide products that meet the needs of the local market.

I'm still learning each day, but I'd like to use my valuable experience to help develop "products that sell."



Masaya Fukuda
FAN R&D
NMB-Minebea-GmbH

■ **Fair and Balanced Evaluation**

At the Minebea Group, impartiality and objectivity are our prime concerns in evaluating the abilities and performance of our employees. Compensation and benefits reflect the results of these evaluations so as to create a workplace where workers can feel that they are performing valuable work and where ambitious employees are encouraged to perform to their maximum potential. We will continue implementing personnel policies based on rewarding effort and

achievement and permitting a flexible response to future changes in the workplace environment and employment structure.

■ **Workforce Diversity**

As the Minebea Group expands its global operations, we believe it is important to strengthen our human resources with diversity as a given. We are committed to creating an environment that maximizes the capabilities of diverse human resources regardless of such attributes as gender, age, nationality, or disability.

● **Developing Global Talent**

The Minebea Group has set a goal to develop and utilize employees who can support global business expansion. As one initiative, the Group is actively hiring foreign exchange students studying at Japanese universities. In FY2012, five of the 60 new employees were non-Japanese.

● **Promoting Female Employment**

Approximately 35,000 female employees are working for the Minebea Group worldwide, accounting for about 70% of our total workforce. For this reason, we will continue to actively work toward the promotion of female employees to management positions, and strive to create a workplace where they can continue to demonstrate their abilities and play an active role.

Special training sessions for female employees were held at the Karuizawa Plant in FY2011 and at the Tokyo headquarters in FY2012. The objective of the training was to have the female employees take a more active role in their work sites by delving into their work site issues and making reform proposals to their supervisors.

■ **Comment from Female Manager**

I'm responsible for customer service in China. The Chinese market is growing by leaps and bounds, and consequently customer demands are becoming more complex. In this business environment, I'm facing new issues daily at my work. But with the collaboration of others in the division, along with my superiors and employees from other divisions, we are finding ways to increase communication with customers and resolve our issues. I'm also the mother of three children, and I'm very pleased to be working at a company where I can both raise children and work. I'd like to use my valuable experience at Minebea to study many new things in the future.



Dora Wong
Senior Manager
Customer Service Management
China Region Sales
Sales Division, China Region
Minebea (Hong Kong) Ltd.

Commitment from the President
 Floods in Thailand
 Minebea Products in Society
 Special Feature
 Management Report
 Social Report
 Environmental Report

Relationships with Employees

● Initiatives Regarding Employees with Disabilities

The Minebea Group actively promotes the employment of people with disabilities, and in January 2011 achieved an employment ratio of 1.88%, surpassing the statutory requirement of 1.8%.

In order to support the motivation of all employees, regardless of whether or not they have a disability, we assign employees with specialized knowledge to take leadership roles at their work sites as part of our policy of considering various factors in making assignments.

▶ Ratio of Employees with Disabilities in the Minebea Group Workforce

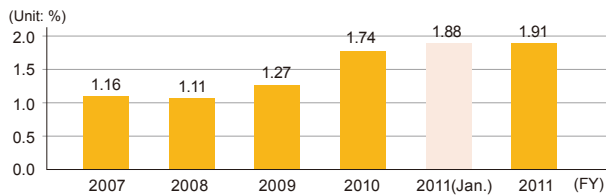

* In the last year's report, the figure for FY2010 represented an annual average for FY2010, while figures for other years were as of June. In this year's report, the figures consistently reflect employment as of June, in accordance with government reports. The Group achieved the statutory requirement of 1.8% in January 2011, and therefore the figure is shown in the graph.

● Initiatives Regarding Reemployment of Seasoned Employees

So that highly skilled and motivated employees may continue working longer, and to enable them to pass on their skills and expertise to younger employees, the retirement age for Minebea Group employees in Japan is 62. Furthermore, in response to the enactment of the Act of Stabilization of Employment of Elderly Persons, the Minebea Group also provides all employees who so desire with an opportunity to be rehired after compulsory retirement.

■ Respect for Human Rights

In light of the importance of corporate compliance (corporate ethics and legal compliance), the Minebea Group prohibits unfair discrimination due to race, age, gender, nationality and religion. Employees undergo training before assignment to regions with different cultures, and the Minebea Group Officer and Employee Compliance Guidelines are used for human rights education at every level of training for employees. Moreover, we are working to prevent human rights abuses by providing a consultation center and an internal reporting system.

■ Initiatives for Creating Environments Conducive to Working

● Support for Diversity in Work Patterns

We believe that the Minebea Group's attention to the

work-life balance of its employees will be rewarding them and lead to a sense of fulfillment.

To this end, we have a flexible system that enables employees to take time off for childbirth, childrearing, caring for family members, and other important events in their private lives. We have also established the Overseas Vacation for Veteran Employees Program, which gives employees who have worked for Minebea for over 30 years an opportunity to rest and recuperate.

The number of users has been increasing year by year, a sign that the system is functioning well.

We will continue to improve the workplace environment so our employees may work with peace of mind.

▶ Principal Special Leave Benefits for Employees in Japan and the Number of Users

(FY2011)

Benefit	Description	No. of employees taking leave
Child care leave	Paid leave or shorter working hours for employees caring for children	60 persons
Family care leave	Paid leave or shorter working hours for employees with family members requiring care	1 person
Overseas vacation for veteran employees	Trip to Thailand, China (Shanghai), or Singapore for employees with 30 years of service, and their families	21 persons

■ Using the Shorter Working Hour System for Child Care

I'm using the system to shorten my morning work hours by 30 minutes in order to care for my child. It takes time for me to commute from my home, so this is just the right system for helping me to take my child to preschool and then get to work. Previously the system fixed the shortened work hours to 45 minutes in the morning and 1 hour at



Shizuyo Tomono
Karuzawa Plant
Personnel & General Affairs Department

night, but from April 2008, we have been able to choose the times with a maximum shortened workday of two hours. Some shorten their days by an hour, others by 1 hour and 45 minutes, and there are those who shorten it by the full 2 hours. Some shorten their hours in the morning or night, and others do both. If the system's easy to use, it makes it easier for us to work, so I think it's important to improve these systems. I'll continue to do my best at both work and childcare, with my child giving me bright smiles and "I love you mom" welcomes.

● Labor Relations

As recited in the Minebea Group Code of Conduct, the Minebea Group recognizes freedom of association and endeavors to build harmonious labor relations by actively communicating with labor unions and employee representatives on issues such as the work environment and working conditions.

■ Health and Occupational Safety Management

The Minebea Group firmly believes that a safe, healthy



workplace is key to improving product and service quality, consistency of manufacturing operations, and employee morale.

Each of our plants has a Health and Safety Committee comprised of numerous working groups with responsibility for workplace safety, health issues, and other such concerns. These committees meet regularly to review working group progress toward individual targets. In addition, the Minebea Group's principal plants in Thailand, China, and Singapore have obtained OHSAS 18001 certification.

In the event of a fire, workplace injury, traffic accident, or other similar incident, safety managers take the lead in identifying the cause and handling the issue appropriately and ensure that information about such incidents is shared with other production sites in each country to prevent similar incidents in the future.

▶ **Workplace Injuries and Other Accidents in the Minebea Group**

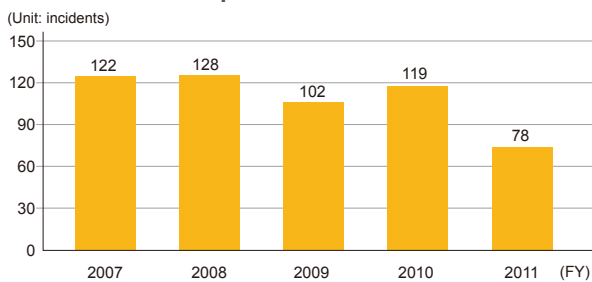

● **Conducting Regular Patrols at Production Facilities**

Regular safety patrols are conducted monthly at every group plant, including the Karuizawa Plant. These patrols monitor progress against the previous month's findings, identify further areas needing improvement, and ensure that areas near production equipment are neat and tidy, that potentially dangerous tools are stored properly, and that safety glasses and earplugs are used.



A patrol at the Fujisawa Plant

● **Promoting Health Management**

The Minebea Group offers regular health examinations and health counseling, and works to ensure and enhance the health of its employees in accordance with the laws of each country and conditions at each place of business; for example, an industrial physician makes regular visits to the Karuizawa Plant. In addition, we are strengthening our initiatives in the mental health field, which in recent years has become an object of heightened social awareness. For example, we offer opportunities for consultation with industrial physicians and industrial counselors, and hold mental health lectures.

● **Health and Occupational Safety Initiatives in China**

At the Zhuhai Plant in China, groups of employees patrol the plant once a month based on the Health and Safety Committee's annual patrol schedule.

The committee also holds a monthly meeting to ensure that accidents that have occurred in other areas of the Minebea Group, as well as similar types of accidents, do not occur at the Zhuhai Plant.

The plant also conducts training drills as required by law. The fire safety subcommittee holds fire drills semiannually, which is very important given the large number of new employees entering the company each year.

Health and safety courses are a required part of the training for new employees. The training helps to instill a proper understanding before the new employees are assigned to a division. Training continues even after employee assignment as part of the daily efforts to prevent accidents at the plant.



Training to prevent leaks of chemical substances during an emergency drill (Zhuhai Plant)

■ **Future Issues and Goals**

We recognize that the training of human resources is an essential element for furthering our global expansion of a stable supply of high-quality precision products generated through manufacturing and technological innovation. Accordingly, we will continue working to convey education and expertise to our employees that can be applied anywhere in the world, and to implement personnel policies to support employees.

- Commitment from the President
- Floods in Thailand
- Minebea Products in Society
- Special Feature
- Management Report
- Social Report
- Environmental Report

Relationships with Local Communities and Global Society

Basic Approach

As an enterprise operating on a global scale, the Minebea Group believes in the importance of building sound partnerships with local communities through good communication. To establish firm roots in those communities, we carry out social contribution activities meeting local needs based upon our Five Principles.

Contributing to Global Society

● Involvement in the Board of Investment Fair 2011

In recognition of the fact that the Minebea Group has continued to actively invest in the country since establishing its Ayutthaya Plant in 1982, the Board of Investment of Thailand* appointed Yoshihisa Kainuma, President and Chief Executive Officer of Minebea, as an honorary investment advisor in June 2010.

In January 2012, the Board of Investment of Thailand held its BOI Fair 2011 under the theme, "Going Green for the Future." President Kainuma participated in the fair's CEO Forum as a panelist to discuss environmental and economic issues during a panel discussion with fellow global business leaders.

* Government agency responsible for promoting investment in Thailand

● Initiatives in North America

Internship program

At the Peterborough Plant in the United States, Minebea offers an internship program for engineering students at local universities.

The purpose of the internship is to give university students the opportunity to put their knowledge to work in a practical setting. The program also offers students the chance to come into contact with businesspeople and understand the type of behavior required of business professionals, thus helping them develop needed skills for the future.

Each year the program selects a few interns from among many applicants.

Participation in CSR Promotion Conference

Our U.S. subsidiary New Hampshire Ball Bearings, Inc. participated in a conference held by the American Bearing Manufacturers Association in April 2011.

Through seminars and exhibits, the conference shared information on leading activities in the areas of energy efficiency and energy saving. The Minebea Group's initiatives were announced at the conference and various case studies were shared among the other attendee companies, enabling the participants to deepen their mutual understanding.

■ Participating in the Conference

There were many events at the conference demonstrating how the bearings industry is tackling environmental problems. We participated in the conference and made a presentation on our initiatives designed to both reduce the environment burden and enhance business performance. The presentation generated a lot of interest among the participants. This was a great opportunity because many companies which typically compete against each other gathered together to cooperate on the issue of the environment. We are confident that these initiatives will help to improve the activities of all the participants.



Patti Carrier (HiTech Div.) and Herb Parkhurst (HiTech Div.) of New Hampshire Ball Bearings, Inc.

● Initiatives in China

Employees provide social welfare support

At the Zhuhai Plant, employee volunteers participate in a program to deliver donated goods to elderly in senior citizen homes and children in welfare facilities.

The volunteers visit the facilities to deliver traditional Chinese cakes and other food supplies to the elderly and children, as well as stationery and other needed goods. The volunteers also spend time talking and enjoying recreation with the facility residents to deepen their friendships.

In addition, plant employees take part in blood drives and other events to support the enhancement of their local community.



Employee volunteers who visited welfare facilities

● Initiatives in Europe

Participation in Frankfurt's Japan Week celebration

2011 marked the 150th anniversary of Japan-Germany relations. Frankfurt, where Minebea has long been active, held a number of cultural exchange events to commemorate the occasion.

The Minebea Group's Germany sales subsidiary acted as a sponsor for the International Friendship Foundation's Japan Week festivities held in Frankfurt in November 2011 as part of the subsidiary's support for cultural exchange events.

Japan Week introduced traditional Japanese dance and tea ceremony to the local community, along with such modern arts as Japanese animation. Additionally, the German community held various events designed to promote mutual understanding and deepen friendship.



● **Initiatives in Thailand**

Support for education

Minebea Group subsidiaries in Thailand contribute to the enhancement of children's education environment through the support of local schools. In FY2011, Group companies made donations to support the establishment of a new community study center in Tak Province. Today, some 150 elementary and junior high school students attend the center.

As a follow-up support activity, employees also visit local community schools twice a year to deliver donated school uniforms and stationery to children, along with bookshelves, chairs, and other needed equipment to the schools. The employees also help repair aging facilities as part of their support for school operations.



Donations to schools supported by the Group

Contributing to Local Communities

● **Promoting Amateur Sports**

Support for Asama Highland Sports Club

The Karuizawa Plant promotes amateur sports by supporting curling. In pursuit of their desire to produce Olympic athletes from Nagano Prefecture, residents of the town of Miyota built a curling rink. Their dream was realized as today, their NPO, Asama Highland Sports Club, acts as a club through membership dues as well as donations from the Karuizawa Plant.

Donations from the plant are used to hold curling tournaments and to support the junior and wheelchair teams.

Curling is rooted in the local community and is a global sport, and the Karuizawa Plant will continue providing support.



A curling tournament supported by the Karuizawa Plant

● **Providing Emergency Shelter**

Being close to the ocean, the Fujisawa Plant cooperates with Fujisawa City to offer its buildings as a tsunami shelter in the event of a natural disaster.

In emergencies, the Fujisawa Plant has the capacity to shelter more than 1,700 residents and tourists.



One of the Fujisawa Plant buildings available as a tsunami shelter

● **Sponsoring the 2011 Fukuroi Enshu Fireworks Festival**

The Hamamatsu Plant supports the annual Fukuroi Enshu Fireworks Festival held by Fukuroi City.

The festival draws the best pyrotechnics from across Japan to compete, providing an exciting event for local residents and supporting the development of the local community through one of the largest festivals of its kind. Based on the theme of "Delivering Messages of Hope," the FY2011 festival donated a part of its revenues to support victims of the Great East Japan Earthquake.

The Hamamatsu Plant will continue to build relations with local residents and support the development of the community.

● **Support for Victims of the Great East Japan Earthquake**

The Minebea Group contributed 50 million yen in earthquake relief funds five days after the Great East Japan Earthquake occurred. Minebea celebrated its 60th anniversary in July 2011, and decided in principle to reallocate the funds earmarked for commemorative business to support reconstruction efforts.

In addition, Minebea Group employees around the world collected 11,960,000 yen in donations.

The Minebea Group will continue to support the reconstruction of the areas devastated by the earthquake.

Future Issues and Goals

By continuing to make active contributions to local communities in and outside Japan, the Minebea Group will strive to be an organization which deepens its community roots and expands sustainably with local communities.

Commitment from the President
Floods in Thailand
Minebea Products in Society
Special Feature
Management Report
Social Report
Environmental Report

Relationships with Suppliers

Basic Approach

The Minebea Group's business is supported by relationships with numerous suppliers. The Minebea Group has adopted Basic Procurement Policies* on which healthy partnerships are built. We also ask our suppliers to comply with the Minebea Group Code of Conduct, which includes provisions regarding respect for human rights, and we aim to encourage environmentally friendly business practices by promoting cooperation for green procurement.

In FY2011, in order to promote CSR throughout the supply chain, we added "CSR Procurement" as the sixth item to our Basic Procurement Policies. In line with this approach, we also established the Minebea Group CSR Procurement Guidelines.

*The Basic Procurement Policies and Minebea Group CSR Procurement Guidelines are published on the Group website.

■ Basic Procurement Policies

<http://www.minebea.co.jp/english/procurements/policy/index.html>

■ Minebea Group CSR Procurement Guidelines

<http://www.minebea.co.jp/english/procurements/csr/index.html>

Supplier Selection Policy

Whenever the Minebea Group initiates a relationship with a new supplier, we ask the supplier to confirm its agreement with our approach to materials procurement and to proceed in accordance with our New Supplier Certification Standards to ensure strict compliance with our Basic Procurement Policies. In particular, we assess suppliers on the basis of ten attributes, including whether or not the company in question will be able to conduct business in a stable, continuous manner, satisfies the Minebea Group Green Procurement Standard, and agrees to abide by the Minebea Group Code of Conduct. Where necessary, we conduct inspections of the supplier's production facilities. In FY2011, we certified a total of 64 suppliers in this manner.

Green Procurement

In July 2004, we established the Minebea Group Green Procurement Standard in response to international laws and directives, to satisfy our customers, and to reduce the use of substances having an environmental impact. Under these guidelines, we require our suppliers to provide products (raw materials, parts, components, and packaging materials) that are free of hazardous substances, and also to submit safety certifications, analysis reports, and other similar documentation. In FY2011, 1,861 suppliers to the overall Minebea Group were cooperating with our Green Procurement policies.

Compliance with the Act against Delay in Payment of Subcontract Proceeds, Etc. to Subcontractors

To ensure the establishment of fair and equitable trading relations with suppliers, in FY2011 the Minebea Group's domestic sites implemented self-auditing of compliance with the Act against Delay in Payment of Subcontract Proceeds, Etc. to Subcontractors. The audits verified that there are no significant violations of the act.

Training was also held at domestic sites to promote a better understanding of the act, with 217 employees participating.



Training session on the Act against Delay in Payment of Subcontract Proceeds, Etc. to Subcontractors

Response to Conflict Minerals from the Democratic Republic of the Congo

Such raw materials as gold, tantalum, tin and tungsten are contained in Minebea Group products, and in some cases such materials may have been extracted in a conflict zone and sold to perpetuate that conflict. The Minebea Group is monitoring U.S. regulatory developments. We have already established a research database and are taking action to respond to this issue, but any formal action, including action by our suppliers, is pending the issuance of guidelines by the U.S. government.

Communication with Suppliers

● CSR Report Distribution

The Minebea Group distributes this CSR report to domestic suppliers to communicate our CSR views. In FY2011, we sent the reports together with questionnaires to 1,641 suppliers and received responses from 69 companies. Questionnaire responses are utilized in the next fiscal year's CSR activities.

Future Issues and Goals

We are striving to establish a CSR procurement framework in order to promote CSR activities throughout the supply chain. As part of the initiative, we plan to distribute a newly created CSR self-assessment checklist to our domestic suppliers and analyze the feedback. We also plan to promote activities through overseas sites.

Relationships with Shareholders

Timely Disclosure/Disclosure Policy

In addition to disclosing information required by applicable laws and regulations in terms of timing and level of detail, Minebea has also established its own disclosure policy to ensure a proactive and fair approach in this regard.

Communication with Shareholders

General Meeting of Shareholders

Minebea's Ordinary General Meeting of Shareholders is held annually in June. In addition, we provide shareholders with semiannual reports to keep them informed of the state of the company's business and our management policies.

Communication with Institutional Investors

Minebea holds investor meetings and conference calls on financial results for institutional investors and securities analysts. This information is also published on our website in Japanese and English, simultaneously or as soon as possible. We also held a meeting in February 2012 to announce our new Medium-term Business Plan.

We spend approximately one week per year in each region visiting investors in North America, Europe, and Asia.

We also participate in brokerage-sponsored investor seminars, conduct numerous one-on-one meetings, and actively engage in many other investor-related activities.

Shareholder Returns

Starting with the appointment of the current president and chief executive officer in FY2009, Minebea has worked toward two goals: maximizing earnings per share and enhancing corporate value, and solidifying the corporate foundation for our centennial. In FY2011, the business environment changed radically due to the impact of the Great East Japan Earthquake and the Thai floods, soaring prices of rare earth materials, and the yen appreciation. In response, we reevaluated our business roadmap and announced the New Medium-term Business Plan. Though the changes to the business environment have resulted in significantly lower revenues and profits, we have maintained an annual dividend of 7 yen per share.

In addition, in November 2008, February 2010, and May to June 2011, we repurchased our shares to enable us to pursue flexible capital policies in response to the changing business environment.

Shareholder Breakdown (as of March 31, 2012)

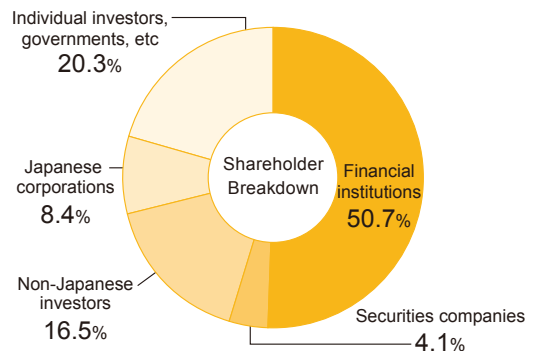

IR Website

Minebea's IR website received Daiwa Investor Relations' "Best Internet IR Company 2011," as well as the "Gomez IR Site Overall Ranking 2012 Gold Award" and "Gomez IR Ranking, No. 2 in Industry" from Morningstar's Gomez Consulting Division.

In addition, Nikko Investor Relations recognized our website with its Top Website Award in the "FY2011 Comprehensiveness Rankings for All Listed Companies."



Future Issues and Goals

Through enhanced IR activities, we will work to expand our communication with shareholders and to promote greater understanding of the Minebea Group among all types of investors.

Environmental Management

Basic Approach

The Minebea Group has established an environmental management system on the basis of which all Group companies strive to conserve the environment.

Minebea's Environmental Philosophy was established as the Group's fundamental policy for environmental protection activities. In FY2012, with the revision of the philosophy's contents, the name was revised to the Minebea Group Environmental Policy. Additionally, we have added "Contributing to Global Society" to the policy. Under this new policy, we will make public our proprietary environmental conservation technologies and raise our awareness of the possible impact of our business activities on biodiversity as we strive to conserve nature.

We put the Minebea Group Environmental Policy into practice through a variety of initiatives, including the use of highly energy-efficient equipment and processes and efforts to reduce emissions of greenhouse gases, chiefly CO₂. In order to protect raw materials, water, and other resources, we are strengthening measures to minimize the emission of waste and effluent from our plants. We are also supplying environmentally conscious products to the market by developing highly energy-efficient motors, lighting, and energy conversion devices, along with development of new materials as well as control technologies and sensors responsible for the energy management of such equipment.

Minebea Group Environmental Policy

Established August 26, 1993
Revised June 01, 2012

The Minebea Group strives to contribute to the protection of the global environment and sustainable human development. In accordance with the Five Principles of its management policy, the Minebea Group operates its business activities in a responsible manner which respects the environment.

① Development and design

The Minebea Group will aim to offer its clients products which contain no hazardous substances for the environment or the health and safety of humans, and which consume as little energy as possible, have high reliability and long life. The Minebea Group will develop and design products which minimize environmental impact over their entire life cycle from the selection of direct and indirect materials and component parts through end use to disposal.

② Manufacturing

For environmentally conscious manufacturing and its continuous improvement, the Minebea Group will improve production yield, reduce product scrap, energy consumption and waste through the 3R concept (Reduce, Reuse and Recycle) and implement preventive measures with regard to pollutants.

③ Procurement and logistics

For environmentally conscious procurement and logistics, the Minebea Group will procure materials including indirect materials and component parts which contain no hazardous substances and employ environmentally friendly logistics systems to minimize environmental impact such as CO₂ emissions.

④ Cooperation with authorities and local public entities

The Minebea Group will observe applicable environmental regulations and rules in the countries and local communities where it is engaged in business. The Minebea Group will contribute to society through participation in its environmental conservation activities.

⑤ Contribution to the international community

The Minebea Group will make public its environmental conservation technologies to contribute to the international community's environmental activities. The Minebea Group will also recognize that its business activities may have an effect on biodiversity and ecosystems and will work to conserve nature.

⑥ Enhancement of environmental conservation awareness among the Minebea Group employees

This environmental policy will be published to the whole Minebea Group. Each employee will be expected to work proactively to conserve the environment.



Environmental Management System

● Environmental Management Structure

In order to carry out the Minebea Group Environmental Policy, the Minebea Group has established an Environmental Management Structure headed by the Board of Directors and the President and Chief Executive Officer. We have also put in place an Environment Management Committee, a promotion organization composed mostly of executive officers, and a Group Environmental Protection Committee, which leads the day-to-day execution of policy. This structure enables rapid response to environmental policy. Each work site also has a Plant General Manager of Environmental Management and a Manager of Environmental Management who promote specific environmental conservation measures at their work sites.

● Environmental Audits

The Minebea Group is striving to acquire ISO 14001 certification at each of its major global sites. In FY2011, the Yonago Plant and Dongguan Chengqu Daiichi Precision Mold Co., Ltd. became the latest sites to acquire certification. To maintain certification, each site is required to conduct an annual external audit by a third-party organization and an annual internal audit by an internal auditor.

For the internal audit, employees with external auditing certification or veteran employees act as instructors. Accordingly, we provide annual training to foster personnel who can conduct these internal audits.



Internal audit at the Yonago Plant

Environmental Education

● Basic Approach and FY2011 Initiatives

The Minebea Group provides training on environmental management basics to all new employees and mid-career hires in order to raise the environmental consciousness of each employee. In addition, all Group employees receive general environmental education

which explains the Minebea Group Environmental Policy along with environmental targets and action plans.

In addition to these programs, we provide training for ISO 14001 internal auditors, waste management education, and drills which simulate natural disasters and other types of emergencies.

● Publication of the Minebea Group's In-house Environmental Newspaper Hello Environment!

Each month, the Minebea Group publishes its in-house environmental newspaper, Hello Environment! Each issue focuses on a particular educational theme with easily understood, instructive articles.

The content includes not only articles on the Group's environmental activities, but practical information on the environment and daily lifestyles. The Group's first environmental newspaper was published by the Hamamatsu Plant in January 2000, and through the March 2012 edition of the Group's in-house environmental newspaper, a total of 142 editions had been published.



The Group's in-house environmental newspaper Hello Environment!

Environmental Accounting

The Minebea Group conducts environmental accounting to confirm its costs for environmental protection activities and the effect of its investments. The Japanese Ministry of the Environment's Environmental Accounting Guidelines 2005 is used as a reference. In FY2011, the Group's environmental conservation costs totaled 3,941 million yen, on par with the cost in FY2010.

▶ Environmental Protection Costs, FY2007 – FY2011

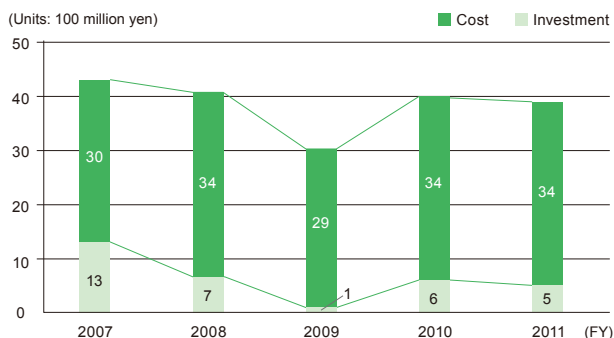

Environmental Management

Initiatives to Protect Biodiversity

In FY2012, the Minebea Group revised its Environmental Policy and added “contribution to the international community” as a new initiative. As part of the initiative, we recognize that our business activities may have an effect on biodiversity and ecosystems, and we will work to conserve nature. One of the important first steps to putting the policy into practice is to research the relation between the Group’s business and biodiversity and understand the impact of our business activities. After determining the impact, we plan to study the creation of an action policy for the Group.

Minebea’s Environmental Impact

The Minebea Group has plants and sales offices in 18 countries around the world, manufacturing and selling a range of products including bearings—our main

product—as well as such products as machined components, rotary components, and electronic devices.

When environmental impact is viewed in terms of the ratio of total production by region to sales, Asia (excluding Japan) is estimated to account for approximately 80% of the Minebea Group’s consumption and output.

In FY2011, the manufacturing facilities in Thailand, the site of the Group’s largest manufacturing operations, suffered damage from local flooding. Of the five manufacturing plants in the country, two were flooded and endured long periods of either suspended activity or limited production. Consequently, the Group’s overall environmental output declined compared to previous years.

The Group’s environmental impact for FY2011 is summarized below.

Input and Output (FY2011 Actual)

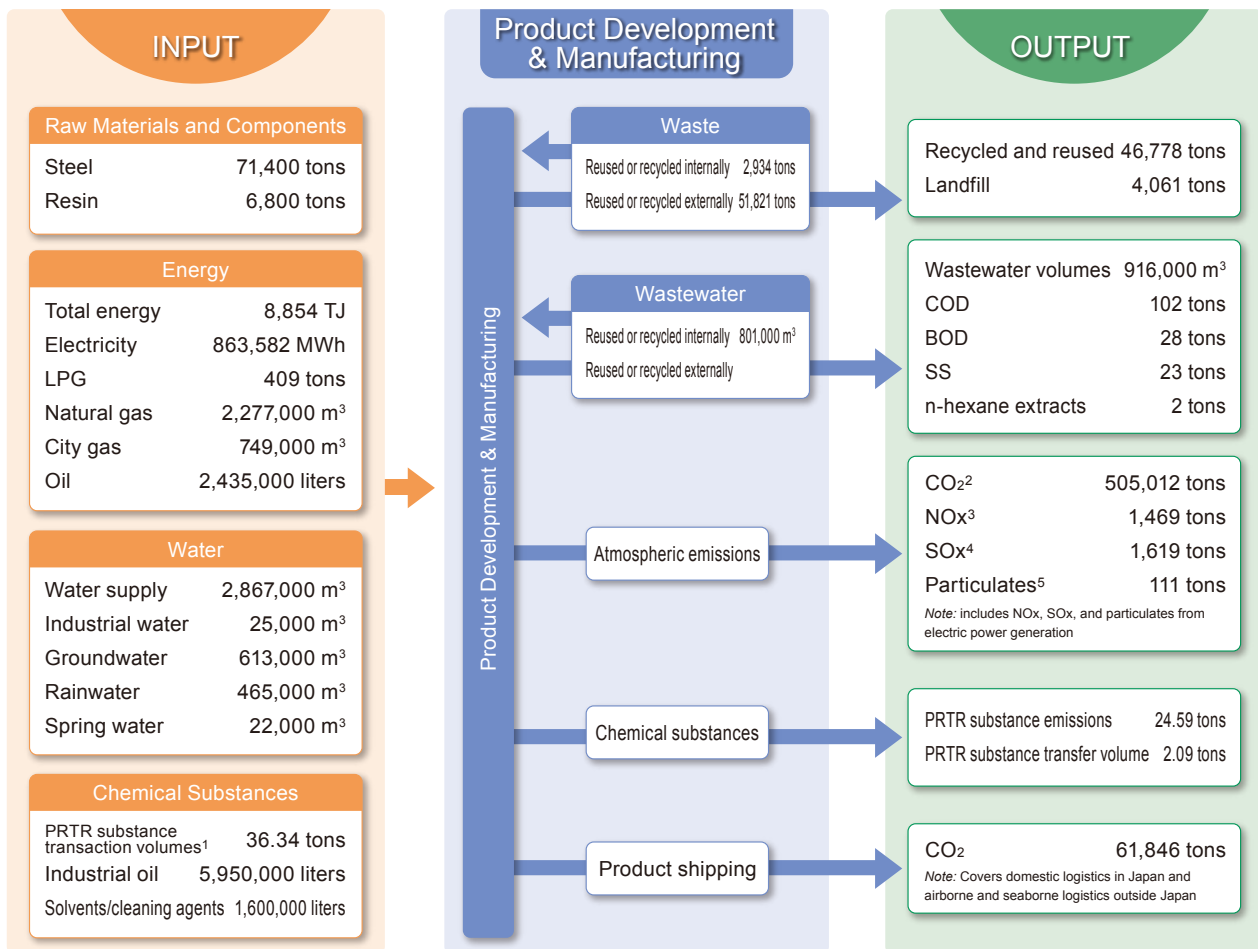

1. **PRTR chemicals:** Substances included in the PRTR law (The Chemical Substance Control Law/Domestic Japanese Law), for which companies must register and report volumes released and transferred.
 2. **CO₂:** Carbon dioxide
 3. **NO_x:** Nitrogen oxides
 4. **SO_x:** Sulfur oxides
 5. **Particulates:** microscopic solid matter contained in exhaust gas generated through combustion, heating, or chemical reaction

Initiatives for Preventing Global Warming

Basic Approach

The Minebea Group recognizes that the international issue of global warming, along with the related issues of soaring energy prices and abnormal climatic conditions, pose a significant threat to the sustainability of its business activities.

In response, each office and plant in the Minebea Group is proactively promoting energy efficiency initiatives in order to combat global warming. Additionally, each site is striving to develop representative initiatives which can be deployed across the Group and has completed implementing initiatives. In January 2010, we formed the Energy Conservation Promotion Committee in order to take global warming prevention measures to the next level across the Group. The committee is comprised of members from every business unit, enabling the sharing of accumulated knowledge, technology, and best energy-saving practices. The spread of knowledge across the business units is strengthening the Group's overall ability to implement global warming prevention measures.

Results of FY2011 Initiatives

The Minebea Group's emissions of CO₂ in FY2011 totaled 505,012 tons, 0.6% less than in FY2010. In terms of basic units of production, CO₂ emissions increased 6.3% over FY2010 to 2.01 tons per million yen of production. The cause of this increase was the negative impact of the Great East Japan Earthquake and the Thai floods on productivity in comparison with FY2010.

In FY2011, the Group also made headway in determining the CO₂ emissions from Group logistics activities. We developed a system to determine the level of emissions from each domestic site on a monthly

basis, as well as a system to compile data on air and sea logistics for overseas sites.

Initiatives at Offices

Response to Power Shortages Following the Great East Japan Earthquake

The shortage of electric power in eastern Japan following the Great East Japan Earthquake of March 11, 2011 has become a serious issue for the nation. In response, the Minebea Group has actively implemented power conservation measures at its Fujisawa, Matsuida, and Omori plants, Tokyo head office, and sales offices within the Tokyo Electric Power Company's service area.

The following are examples of these measures:

- ① Shifting daytime production to nighttime
- ② Reducing the number of lights used
- ③ Shutting down air conditioners and lighting during peak energy consumption hours in the afternoon
- ④ Consolidating work space in order to reduce areas cooled by air conditioners
- ⑤ Allowing employees to wear polo shirts and other cool work attire
- ⑥ Setting up plant curtains near windows to absorb heat



A "green" curtain used to save power (Fujisawa Plant)

CO₂ Emissions (Total and Per Basic Unit)

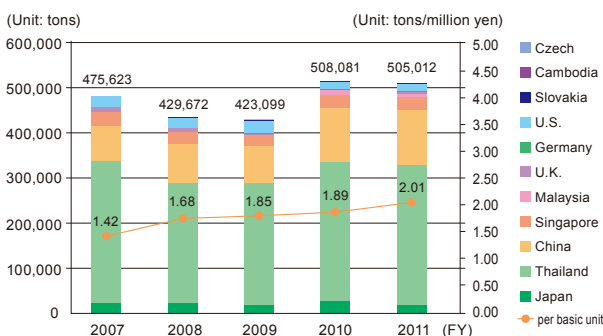

*Emissions generated by product shipment are not included.

Future Issues and Goals

The Minebea Group has set a target of reducing its CO₂ emissions per unit of production by 1% each year in comparison to FY2010, for a total reduction of 5% by FY2015. For FY2012, we have set a goal of establishing a system by which we can regularly report the amount of CO₂ emissions from logistics operations worldwide.

We will also take measures with a long-term outlook for 2030 and 2050, monitoring the Intergovernmental Panel on Climate Change (IPCC) and the policies of various countries.

Initiatives for Effective Use of Resources

Basic Approach

The Minebea Group recognizes that there are limits to the availability of resources used in its products, which include metals, plastics, and other raw materials, along with oil, natural gas, and other energy sources. Additionally, with regard to rare earth elements indispensable to the manufacture of electronics, both the availability and the number of countries exporting the material are limited, making it more susceptible to export restrictions.

We believe that the effective use of resources is critical to the continuation of our business activities, and to that end we are taking various management measures.

Results of FY2011 Initiatives

In FY2011, principal raw materials used by Minebea Group as a whole included approximately 71,400 tons of steel and 6,800 tons of resin, up approximately 8% over the preceding term. The amount of landfill waste generated by the Group's operations in FY2011 totaled 4,061 tons, about the same level as in FY2010 and falling short of our goal of under 4,000 tons.

At our mass production plants in Thailand and China, we are recycling water inside the plants to the greatest extent possible as part of our aim for zero external wastewater emissions. In FY2011, the

Waste Processed in FY2011

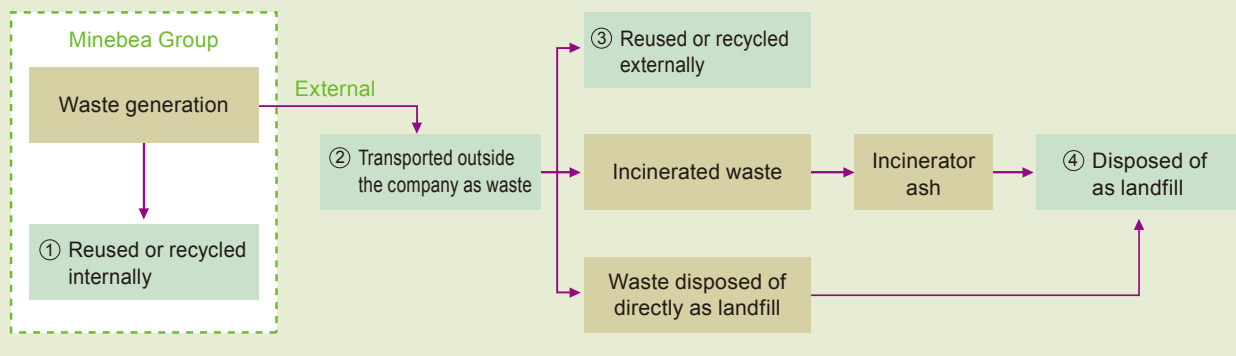
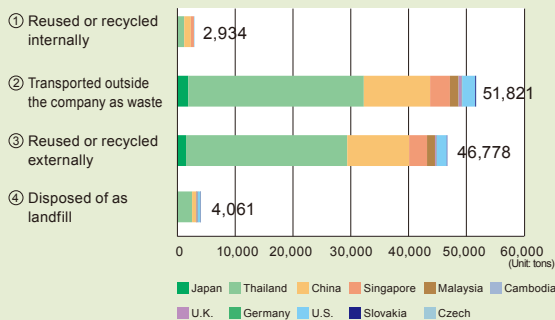

Ayutthaya Plant in Thailand also began implementing the zero emissions system, helping the Group reduce its wastewater emissions by 235,000 tons.

Initiatives at Offices

Accumulated Earnings of 3R Activities Surpass 1 Billion Yen (Shanghai Plant)

The Shanghai Plant launched a Reduce/Reuse/Recycle (3R) Committee in 2003 to effectively reuse and reduce its waste. In the first year of the program's operation, the plant incurred costs to dispose of most of its waste. By separating the waste, however, the plant was able to sell part of it. In the nine years since the program began, the plant has generated earnings of more than 1 billion yen from the sale of its waste.

Shanghai Plant's 3R Earnings



Future Issues and Goals

The Minebea Group is taking measures to reduce the amount of landfill waste it generates.

For FY2012, the Group is aiming to reduce landfill waste to under 4,000 tons, the same target as the previous year. We are currently researching the types of landfill waste being generated and the marketability of the waste, the first steps in our plan to greatly reduce the amount generated over the next several years.

Initiatives for Reducing Impacts on the Environment

Basic Approach

Plant effluents and emissions can be a source of water, air, and soil pollution that poses a threat to local communities. At the Minebea Group, we believe that harmony with the local communities is indispensable to our business activities, and as such, we are striving to reduce the impacts on the environment.

Results of FY2011 Initiatives

In order to ensure compliance with the environmental laws and regulations of each country and community, the Minebea Group has established environmental standards exceeding its legal requirements and undertakes daily compliance monitoring. In FY2011, there were no incidents which violated either the legal requirements or the Group's own standards. The Group also monitors the impact of its plants on the surrounding communities by conducting environmental patrols at all of its plants to ensure there are no leakages, foul odors, noise, or vibration caused by the plants.

Additionally, in FY2011, the Group created a new chemical substances database to more effectively manage the amounts of chemical substances used by the Group. We plan to begin operating the database in FY2012.

Plant Initiatives

Plant Wastewater Purification

Prior to releasing wastewater into rivers, Minebea Group plants use their own wastewater processing equipment to purify wastewater to within fixed environmental standards. These plants adhere to environmental laws of the countries and localities in which they operate, and independently monitor such wastewater discharges, including regular testing for such metrics as pH¹, COD², BOD³, SS⁴, and the oil content of n-hexane extracts⁵.

In FY2011, no anomalous monitored values were reported by any plant. In addition, no complaints relating to these metrics were received.

- pH:** A scale indicating whether substances are acidic or alkaline. pH7 is neutral. pH values below 7 indicate increasing acidity, while values above 7 indicate increasing alkalinity.
- COD (chemical oxygen demand):** The amount of oxygen consumed to oxidize organic substances (pollution) in water. COD measurement takes less time than BOD measurement, but is less reliable. COD is generally used as a metric in wastewater management for sea, lake, and marsh waters.
- BOD (biological oxygen demand):** The amount of oxygen required for bacteria to consume and decompose organic matter (pollution) in water. Higher values indicate greater degrees of pollution. Measurement takes several days. BOD is generally used to observe effluent water in rivers.
- SS (suspended solids):** The volume of substances suspended in water. The higher the number, the greater the degree of water pollution.
- n-hexane extracts:** Substances extracted from oils and detergents that are difficult to volatilize in water using a substance called n-hexane as solvent. In this report they signify mineral oils.

Regular Inspections of Waste and Recycling Stations (Japan, Thailand, China, etc.)

At each plant and office, there are types of waste which are difficult to reuse or recycle within the site. In these cases, the waste is disposed of through third-party waste disposal companies.

The Minebea Group selects reliable waste disposal companies and conducts regular inspections of their disposal sites to confirm the status of waste disposal and management. We will continue to cooperate with waste disposal companies to ensure that their waste disposal processes do not generate soil, water, or air pollution.



Employee of Hamamatsu Plant inspecting a waste disposal site

Completion of Soil Pollution Clean-up at Ichinoseki Plant

In the past, some Minebea Group sites experienced soil and groundwater pollution from the use of chlorinated organic solvents containing volatile organic compounds (VOC). Cleanup of the contaminated plants and plant sites is proceeding under the Minebea Group's auspices.

We confirmed contamination at the Ichinoseki Plant and have voluntarily taken measures to clean up the plant site. The cleanup effort was completed in October 2011, and a report was submitted to the Ichinoseki public health center and the municipal office.



Clean-up work has been completed at the Ichinoseki Plant

Future Issues and Goals

The Minebea Group continues to conduct business operations in compliance with environmental laws in Japan and around the world, and is proceeding with cleanup work in areas where it has caused environmental contamination in the past.

Product-related Initiatives for the Environment

Basic Approach

A majority of the products manufactured by the Minebea Group, such as bearings and motors, are components in products sold by our customers, and are not immediately visible. But precisely because our components are incorporated into such a wide variety of products, the Minebea Group believes it is important to offer products that are safe and free from harmful substances that might damage the environment, while contributing to the overall product life cycle by being energy- and resource-efficient as well as long-lasting.

Minebea Green Products

What are Minebea Green Products?

From the development and design stages, the products that the Minebea Group manufactures and sells are environmentally conscious products, meaning that they satisfy various countries' environmental laws and customers' environmental requirements as well as undergo voluntary product chemical substance evaluations and product assessments.

We are currently formulating certification standards for Minebea Green Products, which demonstrate superior performance and attributes from the perspectives of energy efficiency, contribution to the prevention of global warming, resource efficiency, and contributions to a recycle-oriented society.

Selection Process for Minebea Green Products

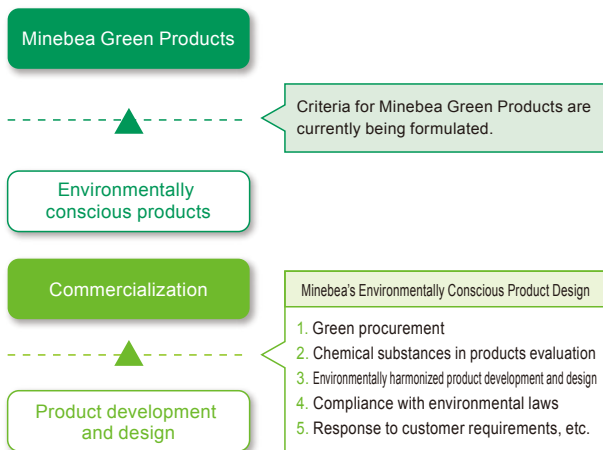

Product Example: Aircraft Bearing Requires No Lubricants

In collaboration with the Nagano Prefecture General Industrial Technology Center, the Minebea Group developed a lubricant-free sliding part for an aircraft bearing which has a low coefficient of friction despite requiring no lubricant such as oil. Minebea's highly durable PTFE* fabric liner and the Nagano Prefecture

General Industrial Technology Center's titanium alloy fortified with carbon nanotube particles were combined to form an exceptionally strong part which demonstrates two-to-three times the life span of conventional products despite being 30% lighter. The product is ideal for contributing to the energy efficiency of aircraft.

*PTFE(Polytetrafluoroethylene)
A resin comprised of fluorine atoms and carbon atoms which shows superior heat and chemical resistance.



Lubricant-free sliding part (product image)

Life Span
2-3 times
conventional products

Weight
30% less than
conventional products

Product Example: Small Digital Converter Module Reduces Energy Consumption by about 85%

The Minebea Group has developed and begun selling a digital converter module, the CSD-892-73, which is one-quarter the size of the Group's previous models and cuts energy consumption by about 85%.

Used in control boards, this digital indicator digitally converts electronic signals from sensors incorporated into factory automation and other equipment and displays the numbers on small modules.

We succeeded in reducing the size and energy consumption of the module by greatly reducing the converter module's operation functions.



Small digital converter module CSD-892-73

Future Issues and Goals

The Minebea Group will continue to accurately grasp the needs of society to make contributions to the development of safe, energy-efficient, and resource-efficient products.

In FY2012, the Group will continue to formulate criteria for selecting Minebea Green Products.

Third-party Opinion

Comments on the Minebea CSR Report



Keisuke Takegahara

Director, Environmental Initiative & Corporate Social Responsibility-Support Department
Development Bank of Japan Inc.

This is the third year since the Minebea Group transitioned from its Environmental Report to the current Minebea Group CSR Report, and this year I find the report has a number of attributes that make it truly epoch-making. In the 2011 report, I came away with a strong impression of Minebea's CSR management and the sudden progress the Group had made in systemizing its CSR efforts. This year, in breaking out the constituent parts, I find a wealth of topics with strong messages elucidating the CSR management of the Minebea Group.

First, this year's report provides a detailed review of the progress on the CSR goals set last year and presents medium-term goals for FY2015. In keeping with the comments of President Kainuma in his executive message, Minebea has laid out the kind of CSR vision a global company should aim for, with goals reflecting the Group's unique character.

Next, the 2012 report takes a thorough approach to disclosing information with an awareness of stakeholders. There were three feature articles emblematic of this. The first was the report on the Group's response to the Thai floods, which revealed the Group's efforts to maintain consistent quality in its manufacturing as well as the strong bonds of trust the Group has built with the local employees through the localization of its operations. I was also impressed with the earnest business continuity management, reflected in the reconstructed timeline from the start of the flooding to the restoration of operations, and the reevaluation of the Group's back-up structure and inventory strategy. This demonstrates Minebea's clear and genuine spirit of responsibility to supplying its customers.

The second article which impressed me was the feature looking back on the Group's business roots upon its 60th

anniversary. This feature gave a strong positive message to a wide group of stakeholders on the roots of Minebea's CSR management.

Finally, the highlight of the report was the excellent article on the supplier dialogue. In conjunction with the establishment of the CSR Procurement Guidelines created in FY2012, this article reflected Minebea's advanced approach of holding dialogues with suppliers to promote CSR throughout the value chain, a hot issue for all companies. The dialogue reflected the consensus view that even if thorough compliance with CSR requests on a broad level, including overseas suppliers, is still a ways away, companies can promote mutual understanding by holding dialogues to understand the basic requirements. The feature conveyed the point that this approach is becoming universal among industries.

There was also more substantial information on social aspects of CSR. The report conveyed the clear addition of "international society" and "nature" as new stakeholders in conjunction with the revision to the Environmental Policy, along with the participation in the Global Compact. Overall, I found many positive changes in this year's report and despite the rich amount of information, the careful selection of topics and division of information between the report and the website made it very concise and easy to read.

Going forward, I would like to see Minebea to strengthen its dialogue with suppliers and establish a CSR model worthy of a global company. In addition to becoming broader, I would like to see the dialogue grow deeper through feedback from suppliers and public disclosure of this progress in a timely fashion. This will support Minebea's advance toward its medium-term goals.

Keisuke Takegahara

After graduation from Hitotsubashi University Faculty of Law, Mr. Takegahara joined the Japan Development Bank (now the Development Bank of Japan, Inc.). He assumed his present post following stints in the bank's Research Department and Policy Planning Department and its Representative Office in Frankfurt. Mr. Takegahara is also a member of several councils, including the Japanese Ministry of the Environment's Environment Industry Market Size Research Committee and the Environment Growth Engine Study Council, along with the Cabinet Office's Future Environmental City Promotion Board and the Future Environmental City Assessment and Research Committee.

On Receiving a Third-party Opinion



Masayuki Imanaka

Managing Executive Officer
Officer in charge of
Finance & Compliance Promotion Division

Mr. Takegahara has been providing us a third-party opinion ever since our first CSR Report was published in FY2010, and each year he has identified important issues regarding our CSR promotion activities.

In our third year of publishing the report, Mr. Takegahara has again provided us with valuable insights and expectations. This year's report included a report on our response to the Thai floods and two feature articles. His

praise of this content has given us confidence moving forward with our initiatives.

One of the issues brought up last year was the formulation of CSR medium-term goals. This year, we provide a progress report on our FY2011 CSR goals as well as our FY2012 and FY2015 medium-term goals, which were created through the establishment of a cross-divisional working team. To meet our FY2015 medium-term targets, we believe it is important to reinforce our PDCA promotion structure for CSR management and, as pointed out, continue to have proactive dialogues with stakeholders.

In terms of the result of our FY2011 goals, we recognize that there are items which we did not achieve and areas requiring further effort. I pledge that we will strive to take our measures to a new level through the continued improvement of our CSR activities.

Minebea

Passion to Exceed Precision

Tokyo Head Office
19F Arco Tower, 1-8-1 Shimo-Meguro,
Meguro-ku, Tokyo 153-8662, Japan
TEL: +81-3-5434-8611
FAX: +81-3-5434-8601
URL: <http://www.minebea.co.jp/>



Printed on paper made with wood from forest thinning. "Morino Chonai-kai" (Forest Neighborhood Association) supports sound forest management.



The Minebea Group supports efforts by Japan's Forestry Agency to reduce CO₂ emissions through the use of domestic forestry products. This report was produced using paper made from Japanese wood products. Active use of such products helps promote the maintenance of Japan's forests and contributes to raising the amount of CO₂ that these forests can absorb.

